



PRODUCT CATALOGUE

 **DATATRONIC**
Innovation by Design

COMPANY INTRODUCTION

CUSTOM

MAGNETICS

EXPERT

DATATRONIC LIMITED

Established in 1971, we have a long history in the design and manufacturing of custom magnetic components for customers worldwide. We have the technical know how to address the everchanging requirements in the industry and our components are used in various performance and quality demanding applications that our customers rely on.

We have factories worldwide to mitigate supply chain risk and pull us closer to customers in different countries and locations. Our factories employ prevention rather than detection philosophy and are quality proven and recognized by reputable customers who gave us numerous awards over the past. We ensure quality and consistency by utilizing automation production processes and we offer good traceability by our shop floor control system.

GROW YOUR BUSINESS WITH US!

DATATRONICS ROMOLAND | USA based factory for the production of parts that are quality demanding. This factory is accredited to AS9100 certificate for manufacturing of components used in the Aerospace industry.

INNOVATIVE POWER | USA based factory for the production of heavy duty components that have a larger size in general. i.e. 3 phase transformers / inductors.

DATATRONIC VIETNAM | Vietnam based factory for high scale production of commercial parts.

DATATRONIC SHUNDE | China based factory for high scale production of commercial and automotive parts.

DATATRONIC ZHONGSHAN | China based factory for high scale production of commercial and medical parts.

QUALIFICATIONS

We possess extensive expertise in custom design and manufacture of micro miniature transformers utilizing wire as small as 56 AWG (.00049 inches, .012 mm) We also manufacture custom transformers with power ratings up to 1000 Watts and large heavy-duty custom transformers for industrial controls and electric power generation systems.

The company's businesses and/or facilities are qualified to some of the industry's most demanding performance, environmental, manufacturing and quality standards for custom magnetics:

STANDARDS & SAFETY AGENCY APPROVALS

- J-STD-001, Class 3 Certified
- MIL-STD-981
- MIL-STD-1553 Databus
- MIL-PRF-27, MIL-PRF-21038
- AEC-Q200
- UL, CA, BABT, CSA
- VDE, TUV

CERTIFICATIONS

DATATRONIC LIMITED

- ISO 9001:2015

DATATRONICS ROMOLAND

- ISO 13485:2016
- AS9100D

INNOVATIVE POWER

- ISO 9001:2015

DATATRONIC SHUNDE CHINA

- ISO9001
- IATF16949

DATATRONIC ZHONGSHAN CHINA

- ISO9001

DATATRONIC VIETNAM

- ISO9001

CUSTOM MAGNETICS CAPABILITIES

Our family of companies specializes in custom magnetics, but also manufactures standard off-the-shelf magnetic components. Our custom and standard products include:

- Air Core Inductors
- Ballast Transformers
- Chokes
- Constant Voltage Transformers
- Current Sense Transformers
- Custom Magnetics
- Distribution Transformers
- Ferro Resonant Transformers
- Fluid Sensors
- Gate Drive Transformers
- High Frequency Inductors
- High Voltage Controls
- High Voltage Transformers
- Inductors
- Isolation Transformers
- MagLev Coils Medical Implantable Coils
- Mil-Std-1553 Data Bus Transformers
- Perfect Layer Coils
- Audio Transformers
- Baluns
- Audio Transformers
- Pickup Coils
- Position Sensors
- Pulse Transformers
- RF Wideband Transformers
- Shielded Inductors
- SMPS Transformers
- Solenoid Coils
- Space & Satellite Magnetics
- Speed Sensors
- Step/Control Transformers
- Telecom Transformers
- Telemetry Coils
- Three Phase Transformers
- Transformers
- Unshielded Inductors





PLANTS AND OFFICES

North America

Datatronics, United States
28151 Highway 74 Menifee, CA 92585
Tel: +951 928 7700

Asia

Datatronic, Hong Kong
19/F, North Point Industrial Building, 499 King's Road, North Point HK
Tel: +852 25648477



01

DATATRONICS ROMOLAND USA | Production of quality demanding parts, certified to AS9100 & ISO 13485



02

DATATRONIC CHINA SHUNDE | High scale production of commercial and automotive parts



03

DATATRONIC CHINA ZHONGSHAN | High scale production of commercial and medical parts



04

DATATRONIC VIETNAM | High scale production of commercial parts

COMPANY MILESTONE

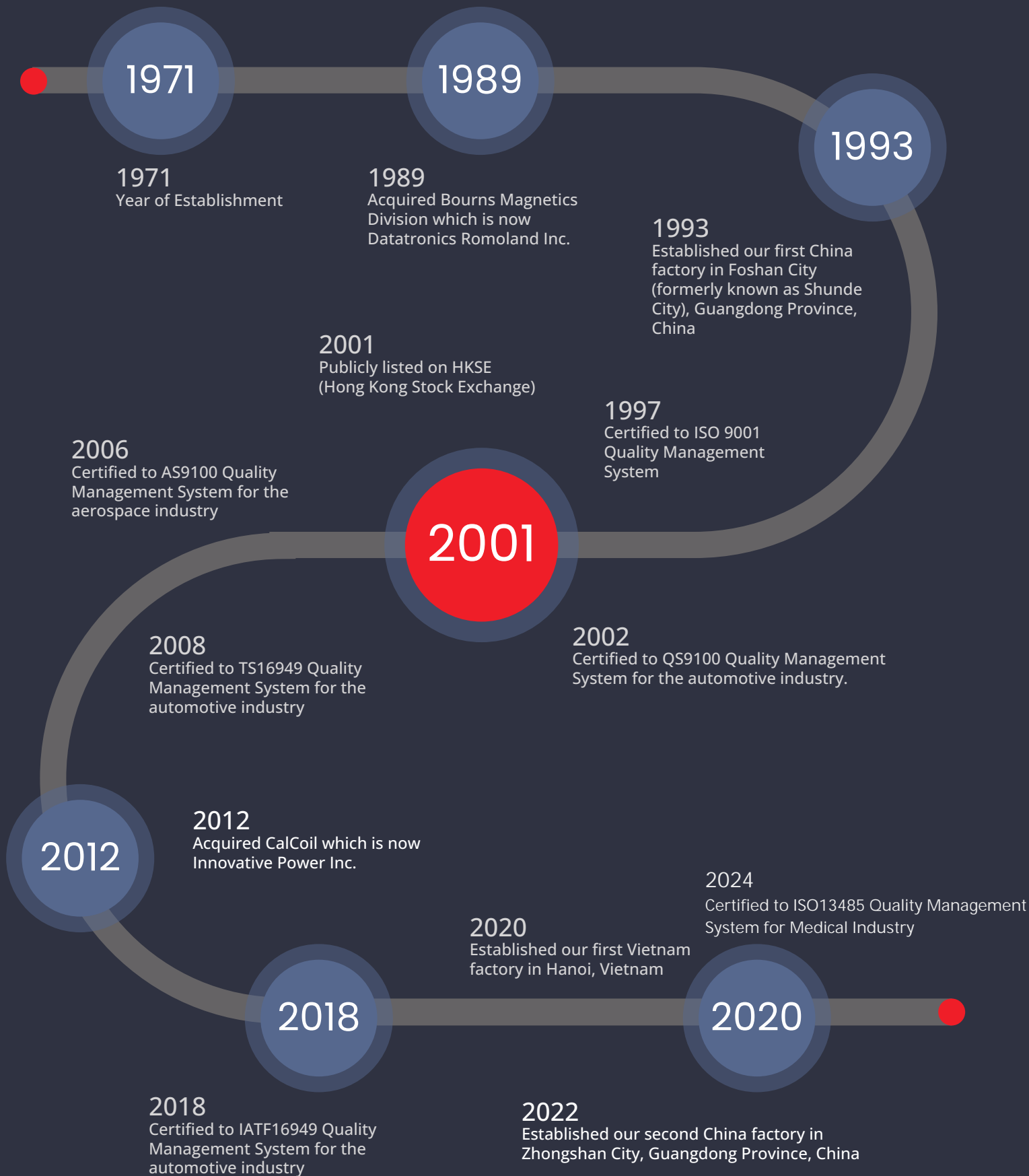

HONORS AND AWARDS

Over the past 50 years, Datatronic has nurtured strong relationships with Fortune 500 companies, solidifying our position as a trusted partner. We take pride in delivering products of exceptional reliability, ensuring that our clients can rely on us for their critical needs. Our unwavering commitment to quality and customer satisfaction has been the foundation of our enduring partnerships with our clients.



Micro Systems



Astronics



Astronics



Dataforth



Astronics



Physio Control



Lutron



Astronics



Micro Systems



Micro Systems



Vicor



Micro Systems



Astronics



Medtronic



Lutron



Dataforth



Xicom



Medtronic



Lutron



Xicom



Lutron



Polycom



Carrier



Xerox



Primex



Xerox



GE



Carrier



Ericsson



Milwaukee



Physio Control



Delco



Harris



Xerox



ICL



Xerox



Bourns



Xerox



Bourns



Digital



Xerox



Xerox



Tektronix



GS Sola

INDEX

STANDARD SERIES

Items	Series Name	Page
CT317	CT317 current sense transformer series	10
CT319	CT319 current sense transformer series	11
CT320	CT320 current sense transformer series	12
CT321	CT321 current sense transformer series	13
CT322	CT322 current sense transformer series	14
CT323	CT323 current sense transformer series	15
DR217-1	DR217-1 inductor series	16
DR217-2	DR217-2 inductor series	18
DR217-3	DR217-3 inductor series	20
DR217-4	DR217-4 inductor series	21
DR217-5	DR217-5 inductor series	22
DR217-6	DR217-6 inductor series	24
DR217-7	DR217-7 inductor series	25
DR217-8	DR217-8 inductor series	26
DR217-9	DR217-9 inductor series	27
DR333	DR333 inductor series	28
DR333-1	DR333-1 inductor series	29
DR334	DR334 inductor series	30
DR335	DR335 inductor series	31
DR336	DR336 inductor series	32
DR337-1	DR337-1 inductor series	33
DR337-2	DR337-2 inductor series	34
DR340-1	DR340-1 inductor series	35
DR340-2	DR340-2 inductor series	36
DR340-3	DR340-3 inductor series	37
DR340-4	DR340-4 inductor series	38
DR340-5	DR340-5 inductor series	39
DR340-6	DR340-6 inductor series	40
DR350-1	DR350-1 inductor series	41
DR350-2	DR350-2 inductor series	42
DR350-3	DR350-3 inductor series	43
DR350-4	DR350-4 inductor series	44
DR350-5	DR350-5 inductor series	45
DR350-6	DR350-6 inductor series	46
DR350-7	DR350-7 inductor series	47
DR350-8	DR350-8 inductor series	48
DR350-9	DR350-9 inductor series	49
DR374-1	DR374-1 inductor series	50

CT317 SERIES

SMD CURRENT SENSE TRANSFORMER



Features

- Low Profile – Height: 4.0mm Max.
- Primary Rated for 6 Amps RMS Max.
- Operating Frequency Range: 10kHz to 1MHz
- Temperature range -40°C to +130°C
- Electrical Specifications @ 25°C
- Tinned Leads with Leaded Solder is Available (note 6)

Part No.	Turns Ratio (±2%)	Inductance (1-3) H (TYP)	DCR(1-3)Ω (MAX)	Hipot Vrms
CT317-020	1:20	100	0.50	500
CT317-030	1:30	230	0.75	500
CT317-040	1:40	440	1.03	500
CT317-050	1:50	670	1.61	500
CT317-060	1:60	1000	1.98	500
CT317-070	1:70	1300	2.97	500
CT317-100	1:100	2800	5.36	500

Mechanical Outline

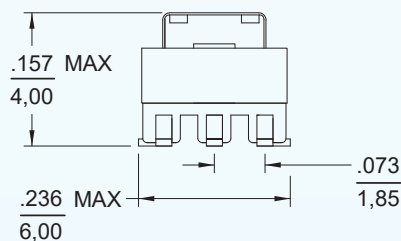
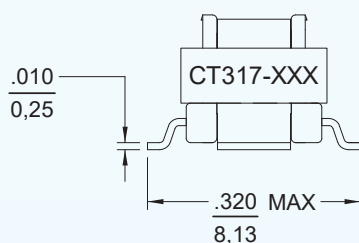
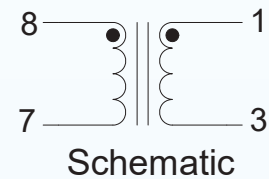
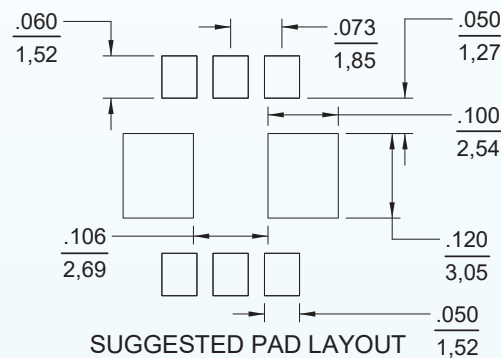
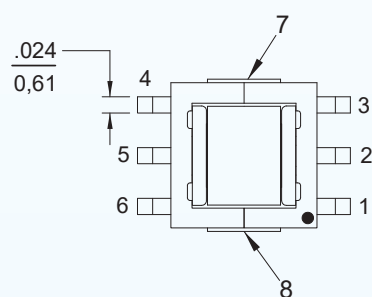

Notes:

- 1.) All dimensions are in inches/mm
Tolerance: 0.010/0,25 unless otherwise specified
- 2.) Inductance tested at 10 kHz, 0.1Vrms
- 3.) Coplanarity: 0.004/0,102
- 4.) Tape and reel quantity, 1200 pcs/reel
- 5.) Terminating resistor (RT) calculated:
 $R_T = (N_{TURNS} / I_{PRI}) * V_{REF}$
- 6.) For Non-RoHS parts, replace CT prefix with -42 e.g. CT317 becomes 42-317
- 7.) Terminal finish compliant to RoHS requirements. Solder in accordance with J-STD-020D

CT319 SERIES

SMD CURRENT SENSE TRANSFORMER



Features

- Low Profile – Height: 4.1mm Max.
- Primary Rated for 20 Amps RMS Max. (note 8)
- Operating Frequency Range: 10kHz to 1MHz
- Temperature range -40°C to +130°C
- Electrical Specifications @ 25°C
- Tinned Leads with Leaded Solder is Available (note 6)

Part No.	Turns Ratio (±2%)	Inductance (4-6) H (TYP)	DCR(4-6)Ω (MAX)	Hipot Vrms
CT319-020	1:20	100	0.50	500
CT319-030	1:30	230	0.75	500
CT319-040	1:40	440	1.03	500
CT319-050	1:50	670	1.61	500
CT319-060	1:60	1000	1.98	500
CT319-070	1:70	1300	2.97	500
CT319-100	1:100	2800	5.36	500

Mechanical Outline

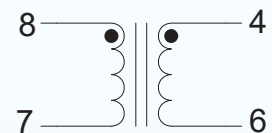
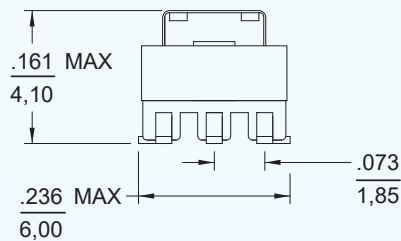
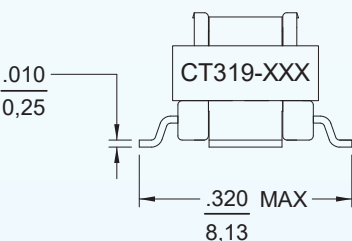
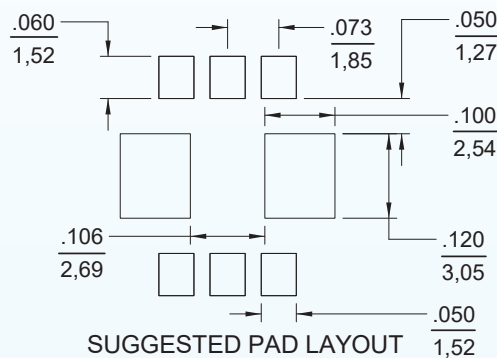
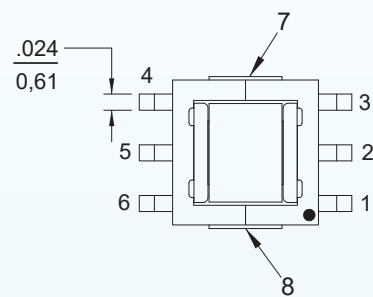

Schematic

Notes:

- 1.) All dimensions are in inches/mm
Tolerance: 0.010/0,25 unless otherwise specified
- 2.) Inductance tested at 10 kHz, 0.1Vrms
- 3.) Coplanarity: 0.004/0,102
- 4.) Tape and reel quantity, 1200 pcs/reel
- 5.) Terminating resistor (RT) calculated:
 $R_T = (N_{\text{TURNS}} / I_{\text{PRI}}) * V_{\text{REF}}$
- 6.) For Non-RoHS parts, replace CT prefix with -42 e.g. CT319 becomes 42-319
- 7.) Terminal finish compliant to RoHS requirements. Solder in accordance with J-STD-020D
- 8.) Primary DCR (~4mΩ) may cause higher voltage than typical for current sensing at high current and higher turns ratios.

CT320 SERIES

SMD CURRENT SENSE TRANSFORMER



Features

- Rated for 35 amps RMS Max.
- Operating Frequency: 50kHz to 500kHz
- Operating Temperature: -40°C to +130°C
- Pick and Place Design
- Tape and Reel Available
- Tinned Leads with Leaded Solder is Available (note 6)

Part No.	Turns Ratio (±2%)	Secondary Inductance (mH TYP)	Primary DCR (mΩ TYP)	Secondary DCR (Ω TYP)	HiPot (Vrms)
CT320-020	1:20	0.30	0.28	1.40	500
CT320-030	1:30	0.66	0.28	2.10	500
CT320-040	1:40	1.20	0.28	2.80	500
CT320-050	1:50	2.00	0.28	3.50	500
CT320-060	1:60	3.00	0.28	4.20	500
CT320-070	1:70	3.90	0.28	4.90	500
CT320-100	1:100	7.50	0.28	7.00	500

Mechanical Outline

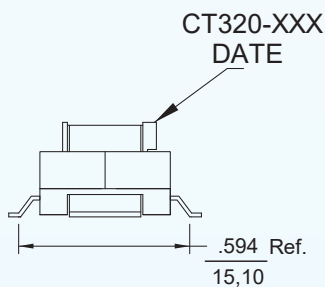
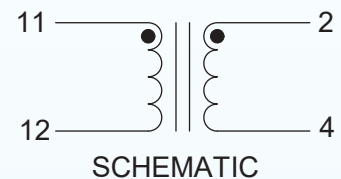
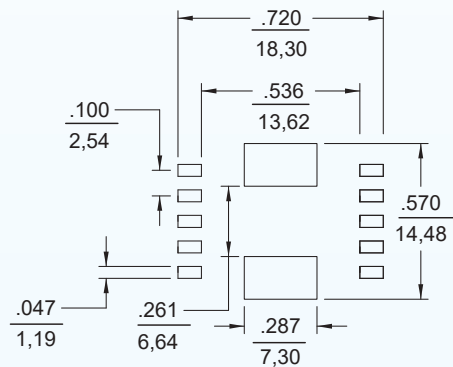
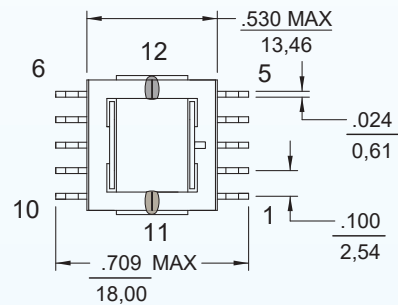

SUGGESTED PAD LAYOUT

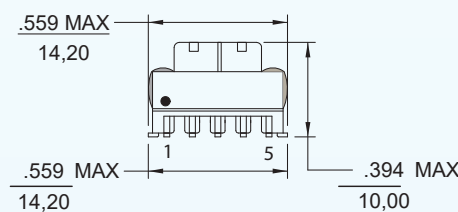

Notes:

- 1.) All dimensions are in inches/mm
Tolerance: 0.010/0,25 unless otherwise specified
- 2.) Inductance tested at 10 kHz, 0.1Vrms
- 3.) Coplanarity: 0.004/0,102
- 4.) Packaging 600 pcs / carton
- 5.) Terminating resistor (RT) calculated:
 $R_T = (N_{\text{TURNS}} / I_{\text{PRI}}) * V_{\text{REF}}$
- 6.) For Non-RoHS parts, replace CT prefix with -42 e.g. CT320 becomes 42-320
- 7.) Terminal finish compliant to RoHS requirements. Solder in accordance with J-STD-020D

CT321 SERIES

SMD CURRENT SENSE TRANSFORMER



Features

- Low Profile – Height: 4.1mm Max.
- Primary Rated for 10 Amps RMS Max. (note 8)
- Operating Frequency Range: 10kHz to 1MHz
- Temperature range -40°C to +130°C
- Electrical Specifications @ 25°C
- Tinned Leads with Leaded Solder is Available (note 6)

Part No.	Turns Ratio (±2%)	Inductance(1-3)μH (TYP)	DCR(1-3)Ω (MAX)	Hipot Vrms
CT321-020	1:20	100	0.50	500
CT321-030	1:30	230	0.75	500
CT321-040	1:40	440	1.03	500
CT321-050	1:50	670	1.61	500
CT321-060	1:60	1000	1.98	500
CT321-070	1:70	1300	2.97	500
CT321-100	1:100	2800	5.36	500

Mechanical Outline

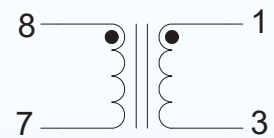

Schematic

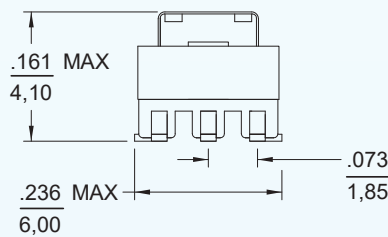
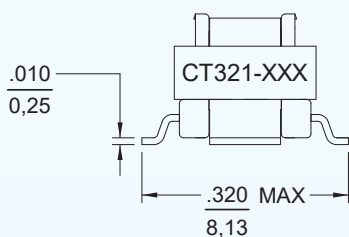
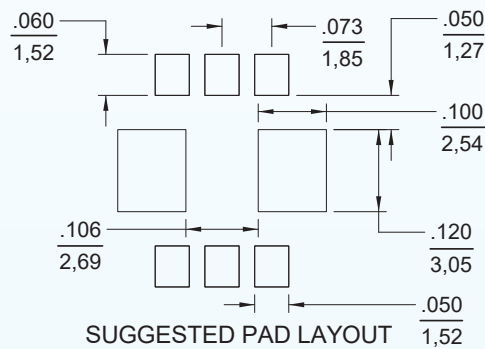
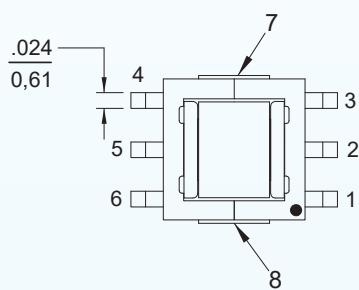

Notes:

- 1.) All dimensions are in inches/mm
Tolerance: 0.010/0,25 unless otherwise specified
- 2.) Inductance tested at 10 kHz, 0.1Vrms
- 3.) Coplanarity: 0.004/0,102
- 4.) Tape and reel quantity, 1200 pcs/reel
- 5.) Terminating resistor (RT) calculated:
 $R_T = (N_{\text{TURNS}} / I_{\text{PRI}}) * V_{\text{REF}}$
- 6.) For Non-RoHS parts, replace CT prefix with -42 e.g. CT321 becomes 42-321
- 7.) Terminal finish compliant to RoHS requirements. Solder in accordance with J-STD-020D
- 8.) Primary DCR (~4mΩ) may cause higher voltage than typical for current sensing at high current and higher turns ratios.

CT322 SERIES

SMD CURRENT SENSE TRANSFORMER



Features

- Low Profile – Height: 4.1mm Max.
- Primary Rated for 20 Amps RMS Max. (note 8)
- Operating Frequency Range: 10kHz to 1MHz
- Temperature range -40°C to +130°C
- Electrical Specifications @ 25°C
- Tinned Leads with Lead Solder is Available (note 6)

Part No.	Turns Ratio (±2%)	Inductance (4-6)μH (TYP)	DCR(4-6) Ω (MAX)	Hipot Vrms
CT322-020	1:20	100	0.50	500
CT322-030	1:30	230	0.75	500
CT322-040	1:40	440	1.03	500
CT322-050	1:50	670	1.61	500
CT322-060	1:60	1000	1.98	500
CT322-070	1:70	1300	2.97	500
CT322-100	1:100	2800	5.36	500

Mechanical Outline

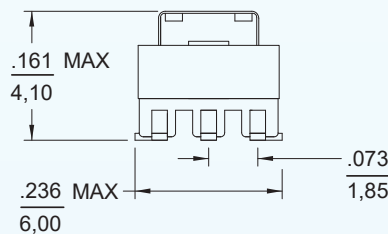
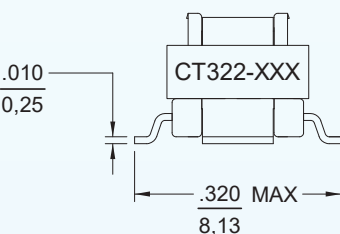
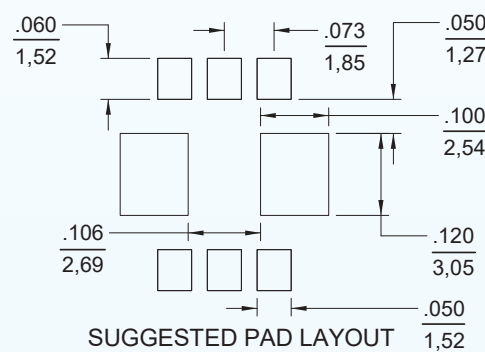
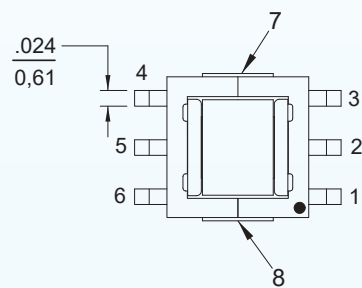
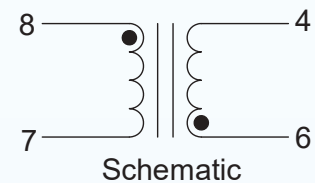

Notes:

- 1.) All dimensions are in inches/mm
Tolerance: 0.010/0,25 unless otherwise specified
- 2.) Inductance tested at 10 kHz, 0.1Vrms
- 3.) Coplanarity: 0.004/0,102
- 4.) Tape and reel quantity, 1200 pcs/reel
- 5.) Terminating resistor (RT) calculated:
 $R_T = (N_{\text{TURNS}} / I_{\text{PRI}}) * V_{\text{REF}}$
- 6.) For Non-RoHS parts, replace CT prefix with -42e.g. CT322 becomes 42-322
- 7.) Terminal finish compliant to RoHS requirements. Solder in accordance with J-STD-020D
- 8.) Primary DCR (~4mΩ) may cause higher voltage than typical for current sensing at high current and higher turns ratios.

CT323 SERIES

SMD CURRENT SENSE TRANSFORMER



Features

- Low Profile – Height: 4.1mm Max.
- Primary Rated for 20 Amps RMS Max. (note 8)
- Operating Frequency Range: 10kHz to 1MHz
- Temperature range -40°C to +130°C
- Electrical Specifications @ 25°C
- Tinned Leads with Lead Solder is Available (note 6)

Part No.	Turns Ratio (±2%)	Inductance (1-3)μH (TYP)	DCR(1-3) Ω (MAX)	Hipot Vrms
CT323-020	1:20	100	0.50	500
CT323-030	1:30	230	0.75	500
CT323-040	1:40	440	1.03	500
CT323-050	1:50	670	1.61	500
CT323-060	1:60	1000	1.98	500
CT323-070	1:70	1300	2.97	500
CT323-100	1:100	2800	5.36	500

Mechanical Outline

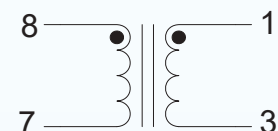

Schematic

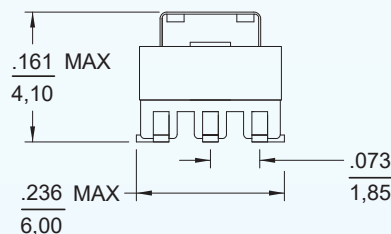
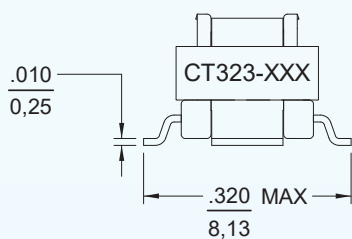
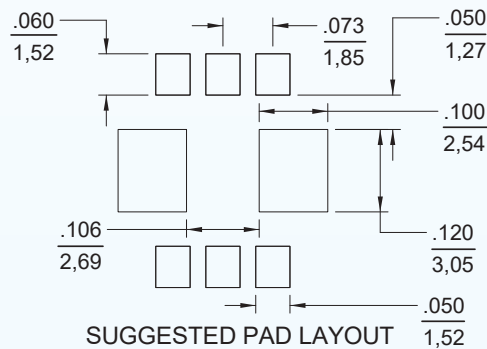
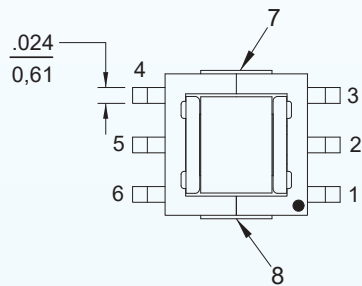

Notes:

- 1.) All dimensions are in inches/mm
Tolerance: 0.010/0,25 unless otherwise specified
- 2.) Inductance tested at 10 kHz, 0.1Vrms
- 3.) Coplanarity: 0.004/0,102
- 4.) Tape and reel quantity, 1200 pcs/reel
- 5.) Terminating resistor (RT) calculated:
 $R_T = (N_{\text{TURNS}} / I_{\text{PRI}}) * V_{\text{REF}}$
- 6.) For Non-RoHS parts, replace CT prefix with -42 e.g. CT323 becomes 42-323
- 7.) Terminal finish compliant to RoHS requirements. Solder in accordance with J-STD-020D
- 8.) Primary DCR (~4mΩ) may cause higher voltage than typical for current sensing at high current and higher turns ratios.

DR217-1 SERIES

RADIAL LEADED INDUCTORS



Features

- Designed for EMI Filters & Switching Power Supplies
- Inductance Range from 1.0 μ H to 25mH
- Operating Temp. -20°C to +80°C
- Tinned Leads with Leaded Solder is Available (note 4)

Electrical Specifications at 25°C

Part No.	Inductance (μ H)@1kHz	Q Min.	Q Test Freq.	SRF (MHz) Min.	DCR (Ohm) Max.	Rated DC Current(A)Max.
DR217-1-102	1.0 \pm 20%	100	7.96MHz	120	0.035	2.00
DR217-1-122	1.2 \pm 20%	100	7.96MHz	120	0.058	1.95
DR217-1-152	1.5 \pm 20%	100	7.96MHz	120	0.075	1.90
DR217-1-182	1.8 \pm 20%	100	7.96MHz	120	0.11	1.80
DR217-1-222	2.2 \pm 20%	100	7.96MHz	100	0.12	1.75
DR217-1-272	2.7 \pm 20%	100	7.96MHz	80	0.125	1.68
DR217-1-332	3.3 \pm 20%	100	7.96MHz	75	0.13	1.50
DR217-1-392	3.9 \pm 10%	100	7.96MHz	70	1.135	1.45
DR217-1-472	4.7 \pm 10%	100	7.96MHz	50	0.14	1.32
DR217-1-562	5.6 \pm 10%	100	7.96MHz	45	0.145	1.23
DR217-1-682	6.8 \pm 10%	100	7.96MHz	30	0.15	1.15
DR217-1-822	8.2 \pm 10%	100	7.96MHz	22	0.16	1.10
DR217-1-103	10 \pm 10%	80	2.52MHz	20	0.23	1.00
DR217-1-123	12 \pm 10%	80	2.52MHz	17	0.24	0.97
DR217-1-153	15 \pm 10%	80	2.52MHz	16	0.25	0.92
DR217-1-183	18 \pm 10%	80	2.52MHz	12	0.33	0.86
DR217-1-223	22 \pm 10%	80	2.52MHz	10	0.45	0.80
DR217-1-273	27 \pm 10%	80	2.52MHz	9.5	0.5	0.71
DR217-1-333	33 \pm 10%	80	2.52MHz	8.7	0.7	0.66
DR217-1-393	39 \pm 10%	70	2.52MHz	8.2	0.74	0.60
DR217-1-473	47 \pm 10%	70	2.52MHz	7.8	0.76	0.55
DR217-1-563	56 \pm 10%	50	2.52MHz	7.6	0.8	0.50
DR217-1-683	68 \pm 10%	50	2.52MHz	6.8	0.9	0.47
DR217-1-823	82 \pm 10%	50	2.52MHz	6	0.95	0.43
DR217-1-104	100 \pm 10%	45	796kHz	6	1	0.40
DR217-1-124	120 \pm 10%	45	796kHz	5.5	1.1	0.37

DR217-1 SERIES

RADIAL LEADED INDUCTORS

Part No.	Inductance (uH)@1kHz	Q Min.	Q Test Freq.	SRF (MHz) Min.	DCR (Ohm) Max.	Rated DC Current (A) Max.
DR217-1-564	560±10%	50	796kHz	1.5	4.2	0.19
DR217-1-684	680±10%	50	796kHz	1.3	4.6	0.17
DR217-1-824	820±10%	50	796kHz	1.1	5.7	0.155
DR217-1-105	1000±10%	100	252kHz	1	6.7	0.15
DR217-1-125	1200±10%	90	252kHz	0.9	8.2	0.14
DR217-1-155	1500±10%	80	252kHz	0.8	13	0.12
DR217-1-185	1800±10%	80	252kHz	0.8	15	0.11
DR217-1-225	2200±10%	80	252kHz	0.8	17	0.10
DR217-1-275	2700±10%	80	252kHz	0.8	19	0.090
DR217-1-335	3300±10%	70	252kHz	0.7	26	0.083
DR217-1-395	3900±10%	70	252kHz	0.65	30	0.076
DR217-1-475	4700±10%	65	252kHz		45	0.070
DR217-1-565	5600±10%	65	252kHz		48	0.062
DR217-1-685	6800±10%	65	252kHz		56	0.056
DR217-1-825	8200±10%	65	252kHz		62	0.052
DR217-1-106	10000±10%	45	79.6kHz		72	0.047
DR217-1-156	15000±10%	45	79.6kHz		120	0.035
DR217-1-226	22000±10%	45	79.6kHz		160	0.024

Mechanical Outline

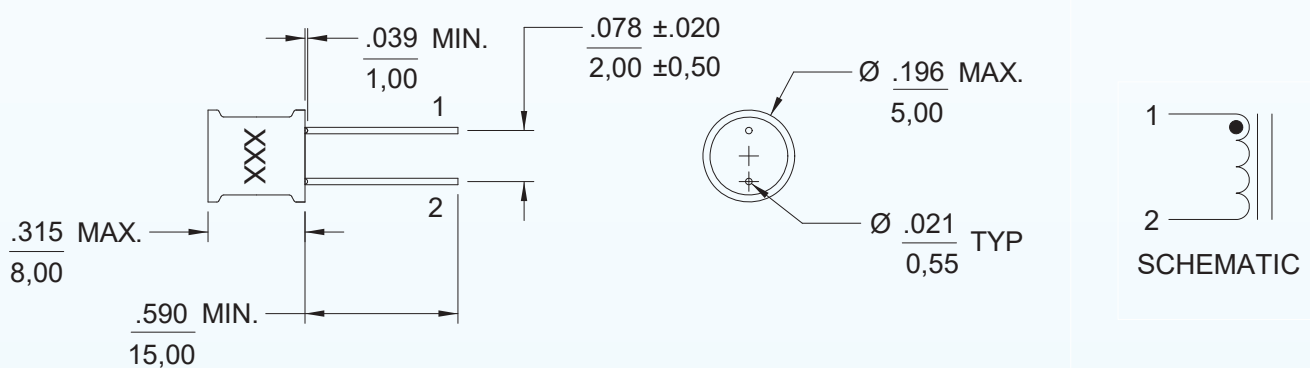

Notes:

1. Dimensions are shown in inches/millimeters
2. Unless otherwise specified, tolerance = Inches: ± 0.012
= Millimeters: $\pm 0,30$
3. IDC MAX based on the inductance being 90% of its initial value
4. For non-RoHS parts replace DR prefix with 42- (e.g. DR217-1 becomes 42-217-1)
5. Terminal finish is compliant to RoHS requirements

DR217-2 SERIES

RADIAL LEADED INDUCTORS



Features

- Designed for EMI Filters & Switching Power Supplies
- Inductance Range from 3.3 μ H to 150mH
- Operating Temp. -20°C to +80°C
- Dielectric Withstand Capability 400VAC
- Tinned Leads with Leaded Solder is Available (note 4)

Electrical Specifications at 25°C

Part No.	Inductance (μ H)@1kHz \pm 20%	Q Min.	Q TestFreq.	DCR(Ohm)Max.	Rated DC Current(A) Max.
DR217-2-332	3.3	20	7.96MHz	0.016	3.50
DR217-2-472	4.7	20	7.96MHz	0.020	3.00
DR217-2-682	6.8	20	7.96MHz	0.022	2.50
DR217-2-103	10	30	2.52MHz	0.039	2.00
DR217-2-153	15	30	2.52MHz	0.045	1.70
DR217-2-223	22	30	2.52MHz	0.062	1.40
DR217-2-333	33	30	2.52MHz	0.10	1.10
DR217-2-473	47	30	2.52MHz	0.15	0.95
DR217-2-683	68	30	2.52MHz	0.22	0.80
DR217-2-104	100	20	796kHz	0.35	0.65
DR217-2-154	150	20	796kHz	0.43	0.54
DR217-2-224	220	20	796kHz	0.90	0.44
DR217-2-334	330	20	796kHz	1.50	0.36
DR217-2-474	470	20	796kHz	1.80	0.30
DR217-2-684	680	20	796kHz	2.50	0.25
DR217-2-105	1000	100	252kHz	3.20	0.20
DR217-2-125	1200	70	252kHz	3.50	0.18
DR217-2-155	1500	70	252kHz	4.50	0.17
DR217-2-185	1800	70	252kHz	5.00	0.155
DR217-2-225	2200	70	252kHz	6.80	0.14
DR217-2-275	2700	70	252kHz	7.20	0.125
DR217-2-335	3300	70	252kHz	10.50	0.115
DR217-2-395	3900	70	252kHz	11.70	0.105
DR217-2-475	4700	70	252kHz	13.60	0.095
DR217-2-565	5600	70	252kHz	16.60	0.085

DR217-2 SERIES

RADIAL LEADED INDUCTORS

Part No.	Inductance (uH)@1kHz	Q Min.	Q Test Freq.	DCR(Ohm)Max.	Rated DC Current(A) Max.
DR217-2-226	22000	50	79.6kHz	60	0.045
DR217-2-306	30000	50	79.6kHz	91.5	0.040
DR217-2-336	33000	50	79.6kHz	98.5	0.035
DR217-2-396	39000	50	79.6kHz	140	0.032
DR217-2-476	47000	50	79.6kHz	160	0.030
DR217-2-506	50000	50	79.6kHz	170	0.029
DR217-2-566	56000	50	79.6kHz	250	0.028
DR217-2-686	68000	50	79.6kHz	282	0.025
DR217-2-826	82000	50	79.6kHz	312	0.023
DR217-2-107	100000	30	25.2kHz	380	0.020
DR217-2-127	120000	30	25.2kHz	430	0.018
DR217-2-157	150000	30	25.2kHz	520	0.016

Mechanical Outline

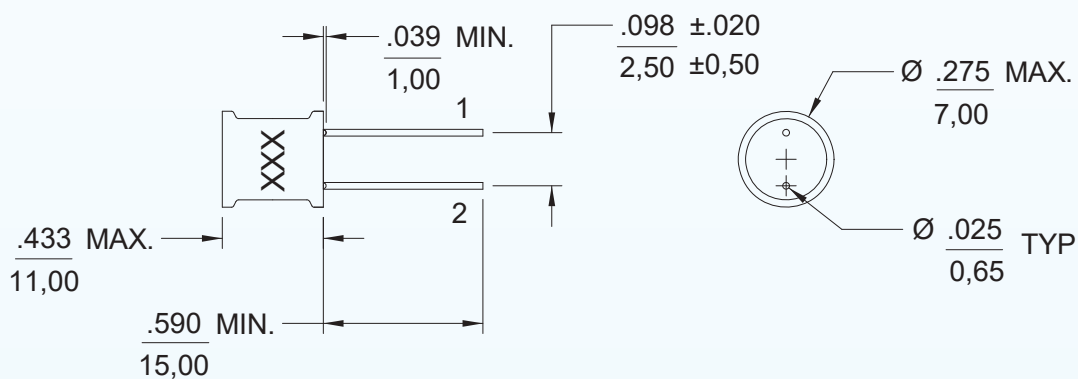

Notes:

1. Dimensions are shown in inches/millimeters
2. Unless otherwise specified, tolerance = Inches: ± 0.012
= Millimeters: $\pm 0,30$
3. IDC MAX based on the inductance being 90% of its initial value
4. For non-RoHS parts replace DR prefix with 42- (e.g. DR217-2 becomes 42-217-2)
5. Terminal finish is compliant to RoHS requirements

DR217-3 SERIES

RADIAL LEADED INDUCTORS



Features

- Designed for EMI Filters & Switching Power Supplies
- Inductance Range from 1.0 μ H to 1500 μ H
- Operating Temp. -20°C to +80°C
- Tinned Leads with Leaded Solder is Available (note 5)

Electrical Specifications at 25°C

Part No.	Inductance (μ H)@1kHz	Q Min.	Q Test Freq.	SRF(MHz) Ref.	DCR(Ohm) Max.	Rated Current (A) Max.Isat	Rated Current(A) Max.Irms
DR217-3-102	1.0 \pm 20%	10	7.96MHz	70	0.006	6.6	5.0
DR217-3-152	1.5 \pm 20%	10	7.96MHz	56	0.008	5.4	4.3
DR217-3-222	2.2 \pm 20%	10	7.96MHz	45	0.011	4.0	3.7
DR217-3-332	3.3 \pm 20%	10	7.96MHz	36	0.018	3.6	2.9
DR217-3-472	4.7 \pm 20%	10	7.96MHz	29	0.022	3.1	2.6
DR217-3-682	6.8 \pm 20%	10	7.96MHz	24	0.028	2.5	2.3
DR217-3-103	10 \pm 10%	20	2.52MHz	19	0.043	2.1	1.9
DR217-3-153	15 \pm 10%	20	2.52MHz	15	0.056	1.7	1.6
DR217-3-223	22 \pm 10%	20	2.52MHz	12	0.086	1.4	1.3
DR217-3-333	33 \pm 10%	20	2.52MHz	9.4	0.14	1.1	1.0
DR217-3-473	47 \pm 10%	20	2.52MHz	7.6	0.17	0.96	0.94
DR217-3-683	68 \pm 10%	20	2.52MHz	6.2	0.28	0.79	0.73
DR217-3-104	100 \pm 10%	20	796kHz	5.0	0.33	0.66	0.67
DR217-3-154	150 \pm 10%	20	796kHz	4.0	0.56	0.53	0.52
DR217-3-224	220 \pm 10%	20	796kHz	3.2	0.72	0.44	0.46
DR217-3-334	330 \pm 10%	20	796kHz	2.5	1.1	0.36	0.37

Mechanical Outline

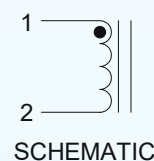
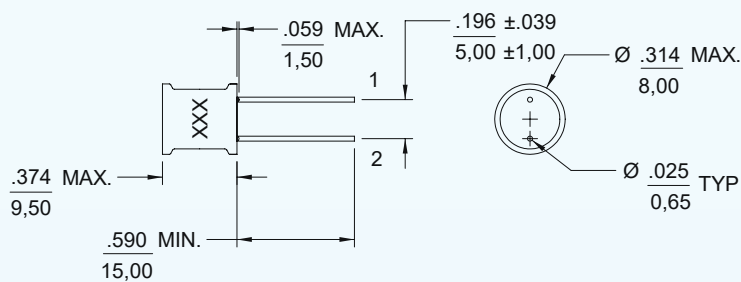

Notes:

1. Dimensions are shown in inches/millimeters
2. Unless otherwise specified, tolerance = Inches: \pm 0.012
= Millimeters: \pm 0,30
3. Isat based on the inductance being 90% of its initial value
4. Irms based on a temperature rise of 20°C
5. For non-RoHS parts replace DR prefix with 42- (e.g. DR217-3 becomes 42-217-3)
6. Terminal finish is compliant to RoHS requirements

DR217-4 SERIES

RADIAL LEADED INDUCTORS



Features

- Designed for EMI Filters & Switching Power Supplies
- Inductance Range from 2.2 μ H to 1500 μ H
- Operating Temp. -20°C to +80°C
- Dielectric Withstand Capability 400VAC
- Tinned Leads with Leaded Solder is Available (note 5)

Electrical Specifications at 25°C

Part No.	Inductance (uH)@1kHz	Q Min.	Q Test Freq.	SRF(MHz) Ref.	DCR(Ohm) Max.	Rated Current (A) Max.Isat	Rated Current(A) Max.I rms
DR217-4-222	2.2 \pm 20%	10	7.96MHz	60	0.011	5.5	4
DR217-4-332	3.3 \pm 20%	10	7.96MHz	38	0.013	3.8	3.4
DR217-4-472	4.7 \pm 20%	10	7.96MHz	30	0.017	3.7	3
DR217-4-682	6.8 \pm 20%	10	7.96MHz	24	0.023	2.8	2.6
DR217-4-103	10 \pm 10%	20	2.52MHz	19	0.031	2.5	2.2
DR217-4-153	15 \pm 10%	20	2.52MHz	15	0.042	2	1.9
DR217-4-223	22 \pm 10%	20	2.52MHz	12	0.07	1.6	1.5
DR217-4-333	33 \pm 10%	20	2.52MHz	10	0.092	1.3	1.2
DR217-4-473	47 \pm 10%	20	2.52MHz	8.2	0.13	1.1	1
DR217-4-683	68 \pm 10%	20	2.52MHz	6.6	0.16	0.91	0.97
DR217-4-104	100 \pm 10%	15	796kHz	5.4	0.23	0.75	0.81
DR217-4-154	150 \pm 10%	15	796kHz	4.3	0.4	0.61	0.61
DR217-4-224	220 \pm 10%	15	796kHz	3.5	0.53	0.5	0.53
DR217-4-334	330 \pm 10%	15	796kHz	2.8	0.78	0.41	0.44
DR217-4-474	470 \pm 10%	10	796kHz	2.3	1	0.34	0.39
DR217-4-684	680 \pm 10%	10	796kHz	1.9	1.5	0.28	0.32

Mechanical Outline

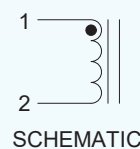
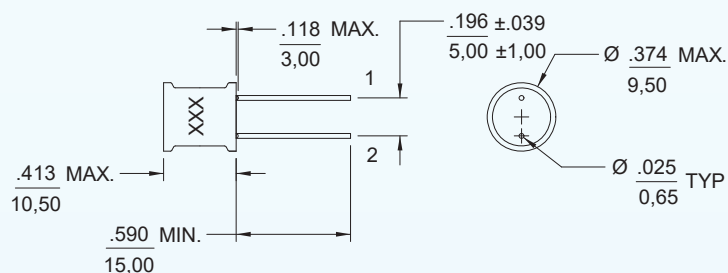

Notes:

1. Dimensions are shown in inches/millimeters
2. Unless otherwise specified, tolerance = Inches: ± 0.012
= Millimeters: $\pm 0,30$
3. Isat based on the inductance being 90% of its initial value
4. Irms based on a temperature rise of 20°C
5. For non-RoHS parts replace DR prefix with 42- (e.g. DR217-4 becomes 42-217-4)
6. Terminal finish is compliant to RoHS requirements

DR217-5 SERIES

RADIAL LEADED INDUCTORS



Features

- Designed for EMI Filters & Switching Power Supplies
- Inductance Range from 3.3 μ H to 100mH
- Operating Temp. -20°C to +80°C
- Tinned Leads with Leaded Solder is Available (note 4)

Electrical Specifications at 25°C

Part No.	Inductance (μ H)@1kHz	Q Min.	Q Test Freq.	SRF (MHz) TYP.	DCR (Ohm) Max.	Rated DC Current(A)Max.
DR217-5-332	3.3 \pm 20%	30	7.96MHz	65	0.012	5.0
DR217-5-392	3.9 \pm 10%	30	7.96MHz	55	0.014	4.6
DR217-5-472	4.7 \pm 10%	30	7.96MHz	45	0.016	4.3
DR217-5-562	5.6 \pm 10%	30	7.96MHz	38	0.02	3.9
DR217-5-682	6.8 \pm 10%	30	7.96MHz	27	0.022	3.7
DR217-5-822	8.2 \pm 10%	30	7.96MHz	21	0.024	3.5
DR217-5-103	10 \pm 10%	50	2.52MHz	17	0.025	3.2
DR217-5-123	12 \pm 10%	50	2.52MHz	15	0.027	3.0
DR217-5-153	15 \pm 10%	50	2.52MHz	13	0.033	2.8
DR217-5-183	18 \pm 10%	50	2.52MHz	12	0.039	2.6
DR217-5-223	22 \pm 10%	50	2.52MHz	11	0.047	2.4
DR217-5-273	27 \pm 10%	50	2.52MHz	10	0.052	2.1
DR217-5-333	33 \pm 10%	50	2.52MHz	8.5	0.075	1.9
DR217-5-393	39 \pm 10%	40	2.52MHz	7.7	0.082	1.7
DR217-5-473	47 \pm 10%	40	2.52MHz	6.7	0.1	1.5
DR217-5-563	56 \pm 10%	40	2.52MHz	6.4	0.15	1.3
DR217-5-683	68 \pm 10%	30	2.52MHz	5.8	0.18	1.2
DR217-5-823	82 \pm 10%	30	2.52MHz	5.2	0.2	1.1
DR217-5-104	100 \pm 10%	30	796kHz	4.4	0.2	0.9
DR217-5-124	120 \pm 10%	30	796kHz	4.2	0.22	0.8
DR217-5-154	150 \pm 10%	30	796kHz	3.7	0.24	0.72
DR217-5-184	180 \pm 10%	30	796kHz	3.5	0.28	0.65
DR217-5-224	220 \pm 10%	20	796kHz	3.3	0.35	0.60
DR217-5-274	270 \pm 10%	20	796kHz	2.9	0.4	0.55
DR217-5-334	330 \pm 10%	20	796kHz	2.6	0.47	0.50

DR217-5 SERIES

RADIAL LEADED INDUCTORS

Part No.	Inductance (uH)@1kHz	Q Min.	Q Test Freq.	SRF (MHz) TYP.	DCR (Ohm) Max.	Rated DC Current(A)Max.
DR217-5-185	1800±10%	40	252kHz	1.1	2.8	0.21
DR217-5-225	2200±10%	40	252kHz	1.0	3.3	0.19
DR217-5-275	2700±10%	40	252kHz	0.88	5	0.17
DR217-5-335	3300±10%	40	252kHz	0.78	5.6	0.15
DR217-5-395	3900±10%	40	252kHz	0.72	6.2	0.14
DR217-5-475	4700±10%	40	252kHz	0.65	7	0.13
DR217-5-565	5600±10%	40	252kHz	0.58	9.1	0.12
DR217-5-685	6800±10%	40	252kHz	0.55	10	0.11
DR217-5-825	8200±10%	20	252kHz	0.5	15	0.10
DR217-5-106	10000±10%	20	79.6kHz	0.42	24	0.09
DR217-5-476	47000±10%	60	79.6kHz	0.20	80	0.04
DR217-5-566	56000±10%	20	79.6kHz	0.10	13.5	0.035
DR217-5-107	100000±10%	20	79.6kHz	0.14	180	0.028

Mechanical Outline

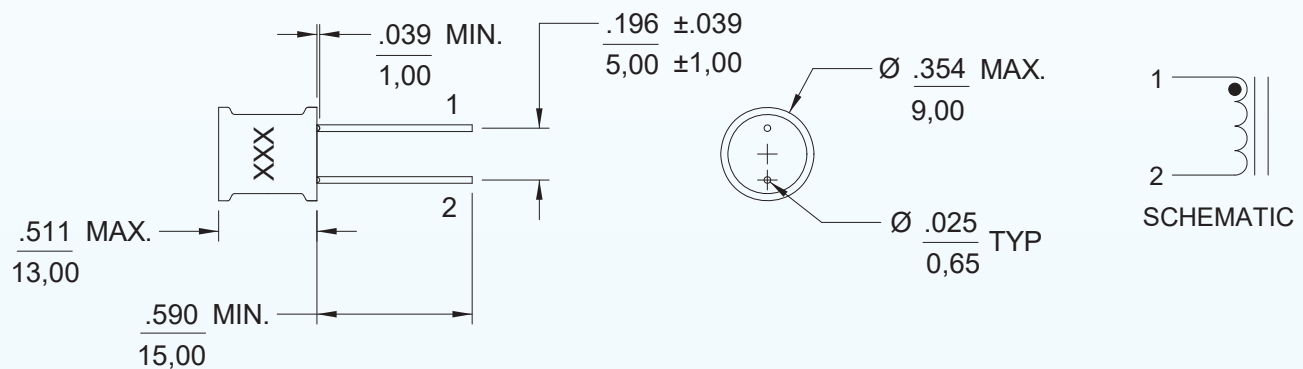

Notes:

1. Dimensions are shown in inches/millimeters
2. Unless otherwise specified, tolerance = Inches: ±0.012
= Millimeters: ±0.30
3. IDC MAX based on the inductance being 90% of its initial value
4. For non-RoHS parts replace DR prefix with 42- (e.g. DR217-5 becomes 42-217-5)
5. Terminal finish is compliant to RoHS requirements

DR217-6 SERIES

RADIAL LEADED INDUCTORS



Features

- Designed for EMI Filters & Switching Power Supplies
- Inductance Range from 3.3 μ H to 15mH
- Operating Temp. -20°C to +80°C
- Tinned Leads with Leaded Solder is Available (note 5)

Electrical Specifications at 25°C

Part No.	Inductance (μ H)@1kHz	Q Min.	Q Test Freq.	SRF(MHz) Min.	DCR(Ohm) Max.	Rated Current (A)Max.Isat	Rated Current (A)Max.Irms
DR217-6-332	3.3 \pm 20%	10	7.96MHz	36	0.01	8.8	5.9
DR217-6-472	4.7 \pm 20%	10	7.96MHz	28	0.015	7.2	4.8
DR217-6-682	6.8 \pm 20%	10	7.96MHz	18	0.016	6.1	4.6
DR217-6-103	10 \pm 20%	20	2.52MHz	16	0.025	5	3.7
DR217-6-153	15 \pm 20%	20	2.52MHz	12	0.029	4.2	3.4
DR217-6-223	22 \pm 10%	20	2.52MHz	9.5	0.04	3.4	2.9
DR217-6-333	33 \pm 10%	30	2.52MHz	7	0.062	2.8	2.3
DR217-6-473	47 \pm 10%	30	2.52MHz	5.8	0.075	2.3	2.1
DR217-6-683	68 \pm 10%	20	2.52MHz	4.7	0.13	1.9	1.6
DR217-6-104	100 \pm 10%	20	796kHz	3.8	0.16	1.6	1.4
DR217-6-154	150 \pm 10%	20	796kHz	3.1	0.26	1.3	1.1
DR207-6-184	180 \pm 10%	20	796kHz	2.8	0.3	1.2	1.05
DR217-6-224	220 \pm 10%	20	796kHz	2.5	0.33	1.1	1
DR217-6-334	330 \pm 10%	20	796kHz	2	0.52	0.88	0.82
DR217-6-474	470 \pm 10%	10	796kHz	1.6	0.66	0.75	0.72
DR217-6-684	680 \pm 10%	10	796kHz	1.3	1.1	0.61	0.56
DR217-6-105	1000 \pm 10%	20	252kHz	1.1	1.4	0.51	0.5

Mechanical Outline

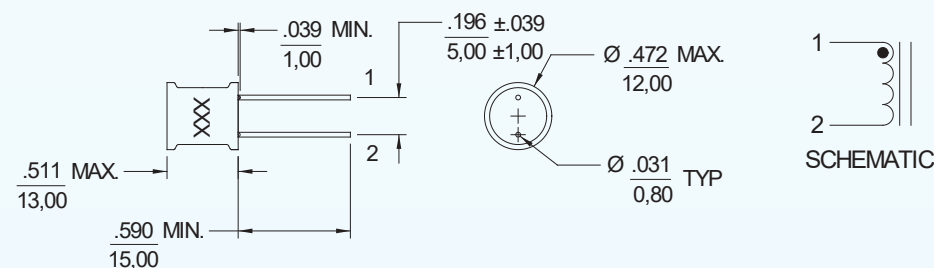

Notes:

1. Dimensions are shown in inches/millimeters
2. Unless otherwise specified, tolerance = Inches: ± 0.012
= Millimeters: $\pm 0,30$
3. I_{sat} based on the inductance being 90% of its initial value
4. I_{rms} based on a temperature rise of 20°C
5. For non-RoHS parts replace DR prefix with 42- (e.g. DR217-6 becomes 42-217-6)
6. Terminal finish is compliant to RoHS requirements

DR217-7 SERIES

RADIAL LEADED INDUCTORS



Features

- Designed for EMI Filters & Switching Power Supplies
- Inductance Range from 10mH to 100mH
- Operating Temp. -20°C to +80°C
- Tinned Leads with Leaded Solder is Available (note 5)

Electrical Specifications at 25°C

Part No.	Inductance (μH)@1kHz ±10%	Q Min.	Q Test Freq.	SRF (MHz) Min.	DCR (Ohm) Max.	Rated Current (A)Max.Isat	Rated Current (A)Max.Irms
DR217-7-106	10000	100	79.6kHz	0.35	12	0.180	0.170
DR217-7-126	12000	100	79.6kHz	0.31	13	0.160	0.160
DR217-7-156	15000	100	79.6kHz	0.28	18	0.140	0.140
DR217-7-186	18000	80	79.6kHz	0.26	25	0.130	0.120
DR217-7-226	22000	80	79.6kHz	0.22	30	0.120	0.110
DR217-7-276	27000	80	79.6kHz	0.20	35	0.110	0.100
DR217-7-336	33000	60	79.6kHz	0.19	40	0.100	0.090
DR217-7-396	39000	60	79.6kHz	0.17	50	0.090	0.080
DR217-7-476	47000	60	79.6kHz	0.15	50	0.080	0.075
DR217-7-566	56000	40	79.6kHz	0.13	65	0.075	0.070
DR217-7-686	68000	40	79.6kHz	0.12	70	0.070	0.065
DR217-7-826	82000	30	79.6kHz	0.10	100	0.060	0.055
DR217-7-107	100000	30	79.6kHz	0.10	135	0.055	0.045

Mechanical Outline

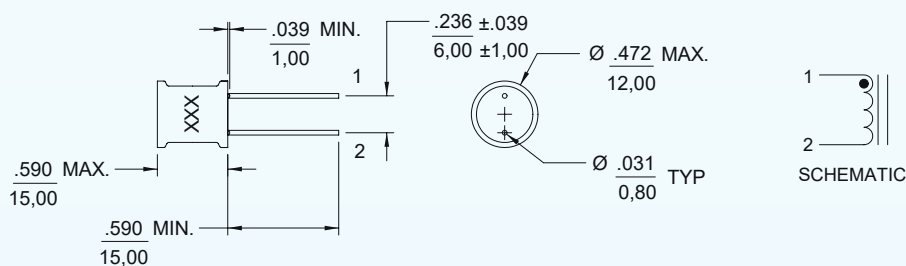

Notes:

1. Dimensions are shown in inches/millimeters
2. Unless otherwise specified, tolerance = Inches: ± 0.012
= Millimeters: $\pm 0,30$
3. I_{sat} based on the inductance being 90% of its initial value
4. I_{rms} based on a temperature rise of 20°C
5. For non-RoHS parts replace DR prefix with 42- (e.g. DR217-7 becomes 42-217-7)
6. Terminal finish is compliant to RoHS requirements

DR217-8 SERIES

RADIAL LEADED INDUCTORS



Features

- Designed for EMI Filters & Switching Power Supplies
- Inductance Range from 4.7 μ H to 100mH
- Operating Temp. -20°C to +80°C
- Tinned Leads with Leaded Solder is Available (note 5)

Electrical Specifications at 25°C

Part No.	Inductance (μ H)@1kHz	DCR(Ohm)Max.	Rated Current(A) Max.Isat	Rated Current(A) Max.Irms
DR217-8-472	4.7	0.008	10.00	6.0
DR217-8-682	6.8	0.011	8.00	5.5
DR217-8-103	10	0.017	7.00	4.5
DR217-8-153	15	0.022	5.50	4.0
DR217-8-223	22	0.026	4.50	3.7
DR217-8-333	33	0.032	3.80	3.3
DR217-8-473	47	0.035	3.20	3.0
DR217-8-683	68	0.047	2.60	2.6
DR217-8-104	100	0.09	2.20	2.0
DR217-8-154	150	0.129	1.80	1.6
DR217-8-224	220	0.162	1.50	1.5
DR217-8-334	330	0.212	1.20	1.2
DR217-8-474	470	0.38	1.00	1.0
DR217-8-684	680	0.548	0.84	0.84
DR217-8-105	1000	0.844	0.66	0.66
DR217-8-155	1500	1.18	0.55	0.55
DR217-8-225	2200	2.0	0.46	0.44
DR217-8-335	3300	2.53	0.38	0.38
DR217-8-475	4700	3.19	0.32	0.32

Mechanical Outline

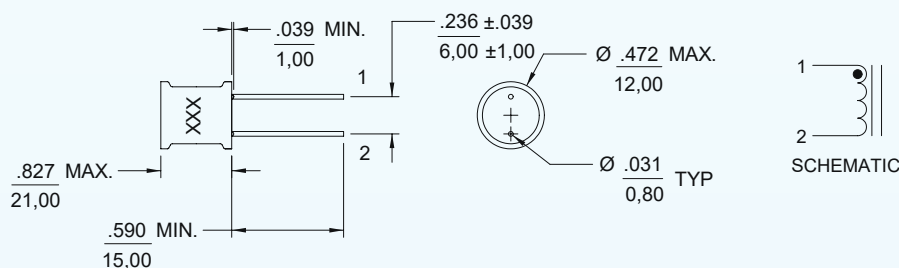

Notes:

1. Dimensions are shown in inches/millimeters
2. Unless otherwise specified, tolerance = Inches: ± 0.012
= Millimeters: ± 0.30
3. I_{sat} based on the inductance being 90% of its initial value
4. I_{rms} based on a temperature rise of 20°C
5. For non-RoHS parts replace DR prefix with 42- (e.g. DR217-8 becomes 42-217-8)
6. Terminal finish is compliant to RoHS requirements

DR217-9 SERIES

RADIAL LEADED INDUCTORS



Features

- Designed for EMI Filters & Switching Power Supplies
- Inductance Range from 10 μ H to 10mH
- Operating Temp. -20°C to +80°C
- Tinned Leads with Leaded Solder is Available (note 5)

Electrical Specifications at 25°C

Part No.	Inductance(μ H) @1kHz	DCR(Ohm) Max.	Rated Current (A)Max.I _{sat}	Rated Current (A)Max.I _{rms}
DR217-9-103	10 \pm 20%	0.023	8	5.1
DR217-9-153	15 \pm 10%	0.028	6.5	4.5
DR217-9-223	22 \pm 10%	0.035	5.5	4.2
DR217-9-333	33 \pm 10%	0.043	4.5	3.7
DR217-9-473	47 \pm 10%	0.052	3.6	3.4
DR217-9-683	68 \pm 10%	0.068	3.1	3.0
DR217-9-104	100 \pm 10%	0.097	2.6	2.5
DR217-9-154	150 \pm 10%	0.14	2.1	2.1
DR217-9-224	220 \pm 10%	0.2	1.7	1.7
DR217-9-334	330 \pm 10%	0.3	1.4	1.4
DR217-9-474	470 \pm 10%	0.43	1.1	1.1
DR217-9-684	680 \pm 10%	0.61	0.95	0.99
DR217-9-105	1000 \pm 10%	1.0	0.78	0.78
DR217-9-155	1500 \pm 10%	1.3	0.64	0.68
DR217-9-225	2200 \pm 10%	2.0	0.53	0.55
DR217-9-335	3300 \pm 10%	3.1	0.43	0.44
DR217-9-475	4700 \pm 10%	4.4	0.36	0.37

Mechanical Outline

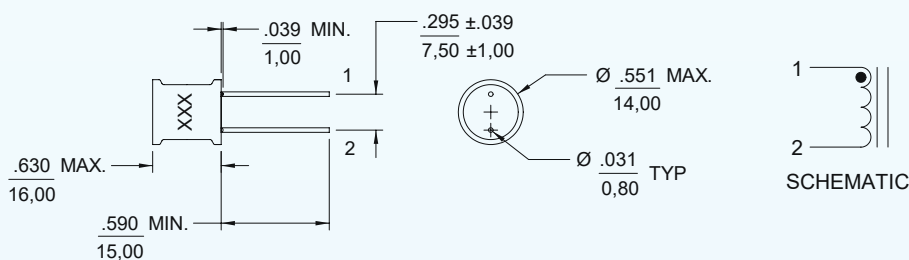

Notes:

1. Dimensions are shown in inches/millimeters
2. Unless otherwise specified, tolerance = Inches: ± 0.012
= Millimeters: ± 0.30
3. I_{sat} based on the inductance being 90% of its initial value
4. I_{rms} based on a temperature rise of 20°C
5. For non-RoHS parts replace DR prefix with 42- (e.g. DR217-9 becomes 42-217-9)
6. Terminal finish is compliant to RoHS requirements

DR333 SERIES

SMD INDUCTOR



Features

- Low Profile Surface Mount Design
- Inductance Range from 1.0 μ H to 68 μ H
- Operating Temp. -20°C to +80°C
- Tinned Leads with Leaded Solder is Available (note 7)

Electrical Specifications at 25°C

Part No.	Inductance (μ H)	DCR (Ω)Max.	RATEDCURRENT (A)Max.
DR333-102	1.0 \pm 20% @7.96MHz,0.25V	0.0487	2.56
DR333-142	1.4 \pm 20% @7.96MHz,0.25V	0.0562	2.52
DR333-182	1.8 \pm 20% @7.96MHz,0.25V	0.0637	1.95
DR333-222	2.2 \pm 20% @7.96MHz,0.25V	0.0712	1.75
DR333-272	2.7 \pm 20% @7.96MHz,0.25V	0.0787	1.58
DR333-332	3.3 \pm 20% @7.96MHz,0.25V	0.0862	1.44
DR333-392	3.9 \pm 20% @7.96MHz,0.25V	0.0937	1.33
DR333-472	4.7 \pm 20% @7.96MHz,0.25V	0.1087	1.15
DR333-562	5.6 \pm 20% @7.96MHz,0.25V	0.1257	0.99
DR333-682	6.8 \pm 20% @7.96MHz,0.25V	0.1312	0.95
DR333-822	8.2 \pm 20% @7.96MHz,0.25V	0.1462	0.84
DR333-103	10 \pm 20% @2.52MHz,0.25V	0.182	1.04
DR333-123	12 \pm 20% @2.52MHz,0.25V	0.210	0.97
DR333-153	15 \pm 20% @2.52MHz,0.25V	0.235	0.85
DR333-183	18 \pm 20% @2.52MHz,0.25V	0.338	0.74
DR333-223	22 \pm 20% @2.52MHz,0.25V	0.378	0.68

Mechanical Outline

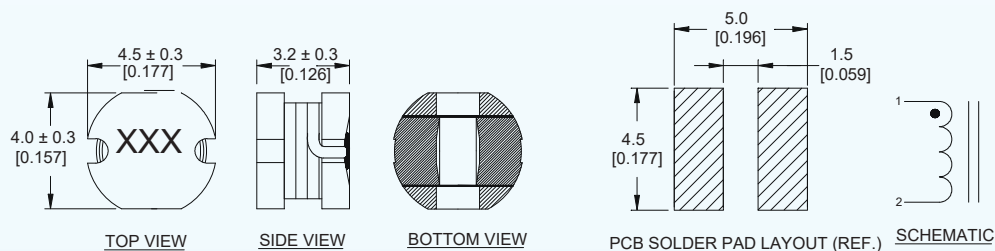

Notes:

1. All dimensions are shown in millimeters "mm" [inches "in"].
2. General tolerance \pm 0.25mm [0.010 in.], unless otherwise specified.
3. I_{rated} for an approximate 40°C temperature rise or 20% drop maximum of the nominal value, whichever is lower.
4. Tape and reel quantity, 2000 pcs/reel.
5. Terminal finish is compliant to RoHS requirements
6. Solder in accordance with J-STD-002 Rev. D
7. Non-RoHS series parts 42-333-XXX are finished with leaded solder Sn60Pb40 or equivalent

DR333-1 SERIES

SMD INDUCTOR



Features

- Low Profile Surface Mount Design
- Inductance Range from 1.0 μ H to 330 μ H
- Operating Temp. -20°C to +80°C
- Tinned Leads with Leaded Solder is Available (note 7)

Electrical Specifications at 25°C

Part No.	Inductance(μ H)	DCR (Ω)Max.	I rated (A)Max.
DR333-1-102	1.0 \pm 20%	@7.96MHz,0.25V 0.045	2.20
DR333-1-122	1.2 \pm 20%	@7.96MHz,0.25V 0.050	2.10
DR333-1-152	1.5 \pm 20%	@7.96MHz,0.25V 0.055	1.70
DR333-1-182	1.8 \pm 20%	@7.96MHz,0.25V 0.070	1.65
DR333-1-222	2.2 \pm 20%	@7.96MHz,0.25V 0.085	1.60
DR333-1-272	2.7 \pm 20%	@7.96MHz,0.25V 0.100	1.40
DR333-1-332	3.3 \pm 20%	@7.96MHz,0.25V 0.120	1.04
DR333-1-392	3.9 \pm 20%	@7.96MHz,0.25V 0.125	1.00
DR333-1-472	4.7 \pm 20%	@7.96MHz,0.25V 0.135	1.00
DR333-1-562	5.6 \pm 20%	@7.96MHz,0.25V 0.145	0.95
DR333-1-682	6.8 \pm 20%	@7.96MHz,0.25V 0.20	0.95
DR333-1-822	8.2 \pm 20%	@7.96MHz,0.25V 0.25	0.92
DR333-1-103	10.0 \pm 20%	@2.52MHz,0.25V 0.32	0.90
DR333-1-123	12.0 \pm 20%	@2.52MHz,0.25V 0.35	0.85
DR333-1-153	15.0 \pm 20%	@2.52MHz,0.25V 0.46	0.75
DR333-1-183	18.0 \pm 20%	@2.52MHz,0.25V 0.52	0.70
DR333-1-223	22.0 \pm 10%	@2.52MHz,0.25V 0.65	0.60
DR333-1-273	27.0 \pm 10%	@2.52MHz,0.25V 0.75	0.55
DR333-1-333	33.0 \pm 10%	@2.52MHz,0.25V 0.92	0.50
DR333-1-393	39.0 \pm 10%	@2.52MHz,0.25V 1.12	0.48
DR333-1-473	47.0 \pm 10%	@2.52MHz,0.25V 1.27	0.45
DR333-1-563	56.0 \pm 10%	@2.52MHz,0.25V 1.50	0.30
DR333-1-683	68.0 \pm 10%	@2.52MHz,0.25V 2.00	0.26
DR333-1-823	82.0 \pm 10%	@2.52MHz,0.25V 2.15	0.23
DR333-1-104	100.0 \pm 10%	@1kHz,0.25V 2.80	0.20
DR333-1-124	120.0 \pm 10%	@1kHz,0.25V 3.40	0.18
DR333-1-154	150.0 \pm 10%	@1kHz,0.25V 4.20	0.16
DR333-1-184	180.0 \pm 10%	@1kHz,0.25V 4.50	0.15
DR333-1-224	220.0 \pm 10%	@1kHz,0.25V 5.70	0.14
DR333-1-274	270.0 \pm 10%	@1kHz,0.25V 8.50	0.10
DR333-1-334	330.0 \pm 10%	@1kHz,0.25V 9.50	0.09

Mechanical Outline

Notes:

- 1.All dimensions are shown in millimeters"mm"[inches"in"].
- 2.General tolerance \pm 0.25mm [0.010 in.], unless otherwise specified.
- 3.I_{rated} for an approximate 40°C temperature rise or 20% drop maximum of the nominal value,
- 4.Tape and reel quantity, 2000 pcs/reel.
- 5.Terminal finish is compliant to RoHS requirements
- 6.Solder in accordance with J-STD-002 Rev. D
- 7.Non-RoHS series parts 42-333-XXX are finished with leaded solder Sn60Pb40 or equivalent

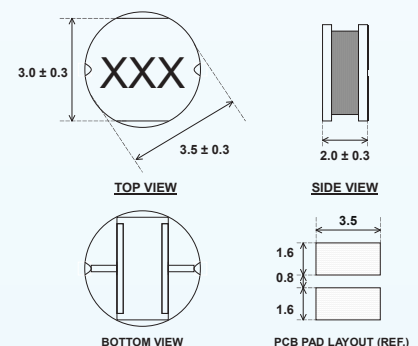

DR334 SERIES

SMD INDUCTOR



Features

- Low Profile Surface Mount Design
- Inductance Range from 4.7 μ H to 1000 μ H
- Operating Temp. -20°C to +80°C
- Tinned Leads with Leaded Solder is Available (note 6)

Electrical Specifications at 25°C

Part No.	Inductance (μ H)	DCR (Ω)Max.	RATED CURRENT (A)Max.
DR334-472	4.7 \pm 20%@7.96MHz,0.1V	0.043	1.50
DR334-103	10 \pm 20%@2.52MHz,0.1V	0.10	1.44
DR334-123	12 \pm 20%@2.52MHz,0.1V	0.12	1.35
DR334-153	15 \pm 20%@2.52MHz,0.1V	0.14	1.30
DR334-183	18 \pm 20%@2.52MHz,0.1V	0.15	1.23
DR334-223	22 \pm 20%@2.52MHz,0.1V	0.18	1.11
DR334-273	27 \pm 20%@2.52MHz,0.1V	0.20	0.97
DR334-333	33 \pm 20%@2.52MHz,0.1V	0.23	0.88
DR334-393	39 \pm 20%@2.52MHz,0.1V	0.32	0.80
DR334-473	47 \pm 20%@2.52MHz,0.1V	0.37	0.72
DR334-563	56 \pm 10%@2.52MHz,0.1V	0.42	0.68
DR334-683	68 \pm 10%@2.52MHz,0.1V	0.46	0.61
DR334-823	82 \pm 10%@2.52MHz,0.1V	0.60	0.58
DR334-104	100 \pm 10%@1kHz,0.1V	0.70	0.52
DR334-124	120 \pm 10%@1kHz,0.1V	0.93	0.48
DR334-154	150 \pm 10%@1kHz,0.1V	1.10	0.40

Mechanical Outline

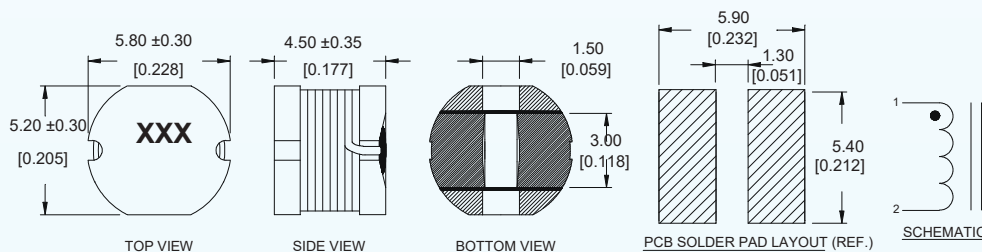

Notes:

1. All dimensions are shown in millimeters "mm"[inches "in"].
2. General tolerance \pm 0.25mm[0.010 IN.], unless otherwise specified.
3. Reel quantity 1500/reel
4. Terminal finish is compliant to RoHS requirements
5. Solder in accordance with J-STD-002 Rev. D
6. Non-RoHS series parts 42-334-XXX are finished with leaded solder Sn60Pb40 or equivalent

DR335 SERIES

SMD INDUCTOR



Features

- Low Profile Surface Mount Design
- Inductance Range from 1.8 μ H to 1000 μ H
- Operating Temp. -20°C to +80°C
- Tinned Leads with Leaded Solder is Available (note 6)

Electrical Specifications at 25°C

Part No.	Inductance (μ H)	DCR (Ω)Max.	RATED CURRENT (A)Max.
DR335-182	1.8 \pm 20% @7.96MHz	0.035	3.50
DR335-272	2.7 \pm 20% @7.96MHz	0.041	3.30
DR335-472	4.7 \pm 20% @7.96MHz	0.048	3.00
DR335-682	6.8 \pm 20% @7.96MHz	0.050	2.70
DR335-822	8.2 \pm 20% @7.96MHz	0.055	2.50
DR335-103	10 \pm 20% @2.52MHz	0.06	2.30
DR335-123	12 \pm 20% @2.52MHz	0.07	2.00
DR335-153	15 \pm 20% @2.52MHz	0.08	1.80
DR335-183	18 \pm 20% @2.52MHz	0.10	1.61
DR335-223	22 \pm 20% @2.52MHz	0.11	1.50
DR335-273	27 \pm 10% @2.52MHz	0.13	1.30
DR335-333	33 \pm 10% @2.52MHz	0.14	1.20
DR335-393	39 \pm 10% @2.52MHz	0.16	1.10
DR335-473	47 \pm 10% @2.52MHz	0.20	1.10
DR335-563	56 \pm 10% @2.52MHz	0.24	0.94
DR335-683	68 \pm 10% @2.52MHz	0.28	0.85
DR335-823	82 \pm 10% @2.52MHz	0.37	0.78
DR335-104	100 \pm 10% @1kHz	0.44	0.72
DR335-124	120 \pm 10% @1kHz	0.47	0.66
DR335-154	150 \pm 10% @1kHz	0.64	0.58
DR335-184	180 \pm 10% @1kHz	0.71	0.51
DR335-224	220 \pm 10% @1kHz	0.96	0.49
DR335-274	270 \pm 10% @1kHz	1.11	0.42
DR335-334	330 \pm 10% @1kHz	1.26	0.40
DR335-394	390 \pm 10% @1kHz	1.77	0.36
DR335-474	470 \pm 10% @1kHz	1.96	0.34
DR335-684	680 \pm 10% @1kHz	2.20	0.25
DR335-105	1000 \pm 10% @1kHz	3.96	0.23

Mechanical Outline

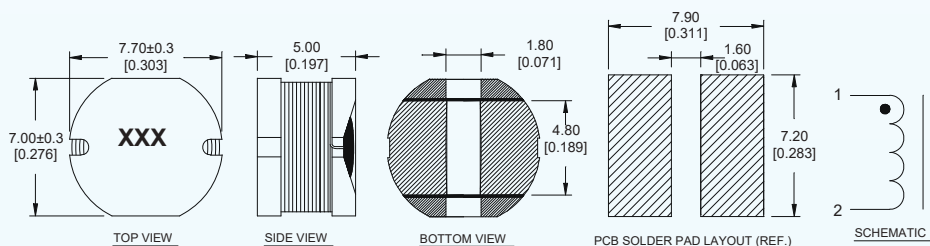

Notes:

1. All dimensions are shown in millimeters "mm" [inches "in"].
2. General tolerance \pm 0.25mm [0.010 in.], unless otherwise specified.
3. Tape and reel quantity, 1000 pcs/reel.
4. Terminal finish is compliant to RoHS requirements
5. Solder in accordance with J-STD-002 Rev. D
6. Non-RoHS series parts 42-335-XXX are finished with leaded solder Sn60Pb40 or equivalent

DR336 SERIES

SMD INDUCTOR



Features

- Low Profile Surface Mount Design
- Flat Top for Pick and Place
- Inductance Range from 10 μ H to 1000 μ H
- Operating Temp. -20°C to +80°C
- Tinned Leads with Leaded Solder is Available (note 6)

Electrical Specifications at 25°C

Part No.	Inductance (μ H)	DCR (Ω)Max.	RATEDCURRENT (A)Max.
DR336-103	10 \pm 20% @2.52MHz	0.08	1.44
DR336-123	12 \pm 20% @2.52MHz	0.09	1.39
DR336-153	15 \pm 20% @2.52MHz	0.10	1.24
DR336-183	18 \pm 20% @2.52MHz	0.11	1.12
DR336-223	22 \pm 20% @2.52MHz	0.13	1.07
DR336-273	27 \pm 20% @2.52MHz	0.17	0.94
DR336-333	33 \pm 20% @2.52MHz	0.18	0.85
DR336-393	39 \pm 20% @2.52MHz	0.22	0.74
DR336-473	47 \pm 20% @2.52MHz	0.25	0.68
DR336-563	56 \pm 20% @2.52MHz	0.28	0.64
DR336-683	68 \pm 10% @2.52MHz	0.33	0.59
DR336-823	82 \pm 10% @2.52MHz	0.45	0.54
DR336-104	100 \pm 10% @1kHz	0.48	0.51

Mechanical Outline

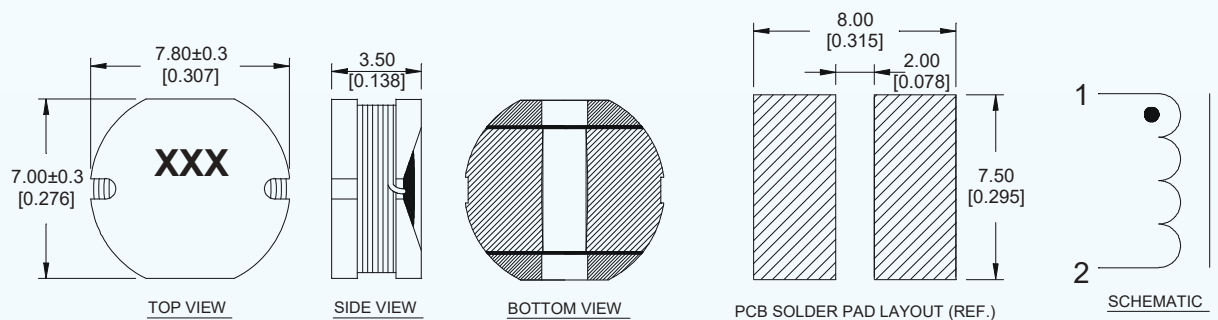

Notes:

1. All dimensions are shown in millimeters "mm" [inches "in"].
2. General tolerance \pm 0.25mm [0.010 IN.], unless otherwise specified.
3. Tape and reel quantity, 1000 pcs/reel.
4. Terminal finish is compliant to RoHS requirements
5. Solder in accordance with J-STD-002 Rev. D
6. Non-RoHS series parts 42-336-XXX are finished with leaded solder Sn60Pb40 or equivalent

DR337-1 SERIES

SMD INDUCTOR



Features

- Low Profile Surface Mount Design
- Flat Top for Pick and Place
- Inductance Range from 10 μ H to 560 μ H
- Operating Temp. -20°C to +80°C
- Tinned Leads with Leaded Solder is Available (note 6)

Electrical Specifications at 25°C

Part No.	Inductance (μ H)	DCR (Ω)Max.	RATEDCURRENT (A)Max.
DR337-1-103	10 \pm 20% @2.52MHz,0.1V	0.053	2.40
DR337-1-123	12 \pm 20% @2.52MHz,0.1V	0.061	2.20
DR337-1-153	15 \pm 20% @2.52MHz,0.1V	0.070	1.90
DR337-1-183	18 \pm 20% @2.52MHz,0.1V	0.081	1.80
DR337-1-223	22 \pm 20% @2.52MHz,0.1V	0.088	1.60
DR337-1-273	27 \pm 20% @2.52MHz,0.1V	0.100	1.50
DR337-1-333	33 \pm 20% @2.52MHz,0.1V	0.120	1.30
DR337-1-393	39 \pm 20% @2.52MHz,0.1V	0.151	1.20
DR337-1-473	47 \pm 10% @2.52MHz,0.1V	0.170	1.10
DR337-1-563	56 \pm 10% @2.52MHz,0.1V	0.199	1.00
DR337-1-683	68 \pm 10% @2.52MHz,0.1V	0.223	0.91
DR337-1-823	82 \pm 10% @2.52MHz,0.1V	0.252	0.85
DR337-1-104	100 \pm 10% @1kHz,0.1V	0.344	0.74
DR337-1-124	120 \pm 10% @1kHz,0.1V	0.396	0.69
DR337-1-154	150 \pm 10% @1kHz,0.1V	0.544	0.61

Mechanical Outline

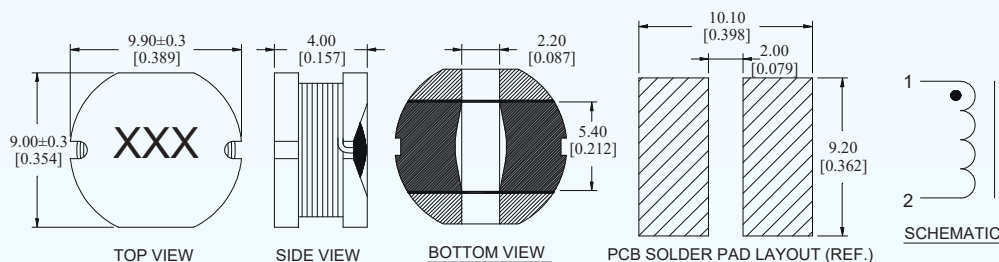

Notes:

1. All dimensions are shown in millimeters "mm" [inches "in"].
2. General tolerance \pm 0.25mm [0.010 IN.], unless otherwise specified.
3. Tape and reel quantity, 750 pcs/reel.
4. Terminal finish is compliant to RoHS requirements
5. Solder in accordance with J-STD-002 Rev. D
6. Non-RoHS series parts 42-337-1-XXX are finished with leaded solder Sn60Pb40 or equivalent

DR337-2 SERIES

SMD INDUCTOR



Features

- Low Profile Surface Mount Design
- Inductance Range from 8.2 μ H to 1200 μ H
- Operating Temp. -20°C to +80°C
- Tinned Leads with Leaded Solder is Available (note 6)

Electrical Specifications at 25°C

Part No.	Inductance (μ H)	DCR (Ω)Max.	RATED CURRENT (A)Max.
DR337-2-822	8.2 \pm 20% @7.96MHz,0.1V	0.05	2.70
DR337-2-103	10 \pm 20% @2.52MHz,0.1V	0.06	2.60
DR337-2-123	12 \pm 20% @2.52MHz,0.1V	0.07	2.45
DR337-2-153	15 \pm 20% @2.52MHz,0.1V	0.08	2.27
DR337-2-183	18 \pm 20% @2.52MHz,0.1V	0.09	2.15
DR337-2-223	22 \pm 20% @2.52MHz,0.1V	0.10	1.95
DR337-2-253	25 \pm 20% @2.52MHz,0.1V	0.10	1.85
DR337-2-273	27 \pm 20% @2.52MHz,0.1V	0.11	1.76
DR337-2-333	33 \pm 20% @2.52MHz,0.1V	0.13	1.56
DR337-2-393	39 \pm 20% @2.52MHz,0.1V	0.14	1.37
DR337-2-473	47 \pm 10% @2.52MHz,0.1V	0.17	1.28
DR337-2-563	56 \pm 10% @2.52MHz,0.1V	0.19	1.17
DR337-2-683	68 \pm 10% @2.52MHz,0.1V	0.22	1.11
DR337-2-823	82 \pm 10% @2.52MHz,0.1V	0.25	1.00
DR337-2-104	100 \pm 10% @1kHz,0.1V	0.35	0.97
DR337-2-124	120 \pm 10% @1kHz,0.1V	0.41	0.89
DR337-2-154	150 \pm 10% @1kHz,0.1V	0.47	0.78
DR337-2-184	180 \pm 10% @1kHz,0.1V	0.63	0.72

Mechanical Outline

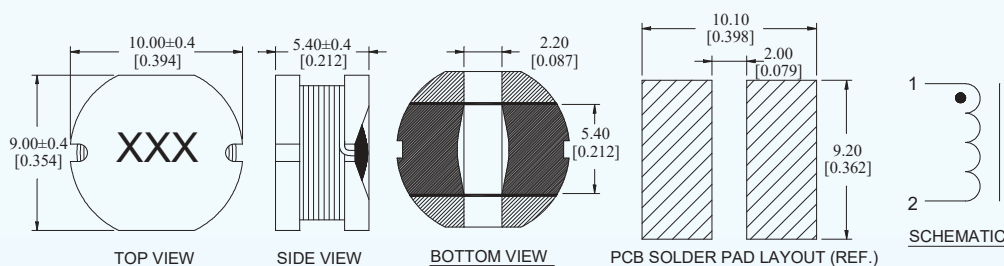

Notes:

1. All dimensions are shown in millimeters "mm" [inches "in"].
2. General tolerance \pm 0.25mm [0.010 in.], unless otherwise specified.
3. Tape and reel quantity, 750 pcs/reel.
4. Terminal finish is compliant to RoHS requirements
5. Solder in accordance with J-STD-002 Rev. D
6. Non-RoHS series parts 42-337-2-XXX are finished with leaded solder Sn60Pb40 or equivalent

DR340-1 SERIES

SHIELDED POWER INDUCTOR



Features

- Low Profile Surface Mount Design
- Inductance Range from 8.2 μ H to 1200 μ H
- Operating Temp. -20°C to +80°C
- Tinned Leads with Leaded Solder is Available (note 6)

Electrical Specifications at 25°C

Part No.	Inductance(μ H)	Test Frequency	DCR(Ω)Max.	IDC(A)Max.
DR340-1-122	1.2+40%/-20%	100kHz	0.007	9.80
DR340-1-242	2.4+40%/-20%	100kHz	0.012	8.00
DR340-1-352	3.5+40%/-20%	100kHz	0.014	7.50
DR340-1-472	4.7+40%/-20%	100kHz	0.016	6.80
DR340-1-612	6.1+40%/-20%	100kHz	0.018	6.60
DR340-1-762	7.6+40%/-20%	100kHz	0.020	5.90
DR340-1-103	10 \pm 20%	1kHz	0.022	5.40
DR340-1-123	12 \pm 20%	1kHz	0.025	4.90
DR340-1-153	15 \pm 20%	1kHz	0.027	4.50
DR340-1-183	18 \pm 20%	1kHz	0.040	3.90
DR340-1-223	22 \pm 20%	1kHz	0.044	3.60
DR340-1-273	27 \pm 20%	1kHz	0.046	3.40

Mechanical Outline

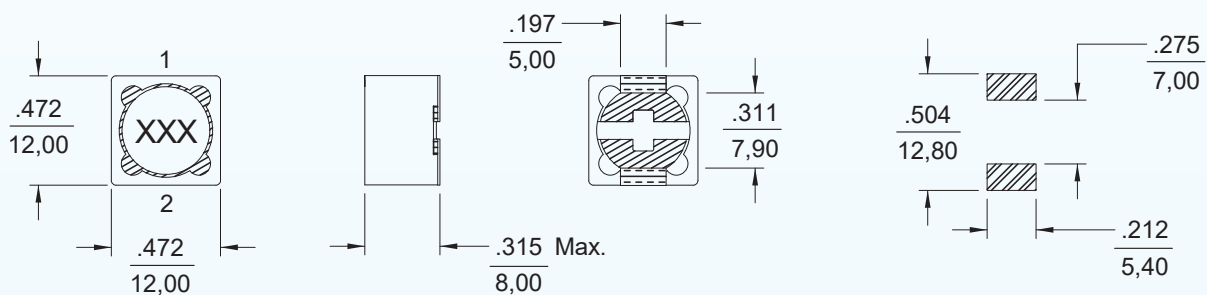

Notes:

1. Dimensions are shown in inches/millimeters
2. Unless otherwise specified, tolerance = Inches: ± 0.012
= Millimeters: ± 0.30
3. IDC MAX based on the inductance being 75% of its initial value
4. Tape & reel quantity, 350 pcs/reel
5. Terminal finish is compliant to RoHS requirements
6. Solder in accordance with J-STD-002 Rev. D
7. Non-RoHS series parts 42-340-1-XXX are finished with leaded solder Sn60Pb40 or equivalent

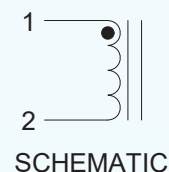

DR340-2 SERIES

SHIELDED POWER INDUCTOR



Features

- Maximum Height: 4.50mm
- Footprint: 12mm x 12mm Max.
- Inductance Range from 3.9 μ H to 330 μ H
- Non-RoHS Versions are Available (Note 7)
- Operating Temp. -20°C to +80°C

Electrical Specifications at 25°C

Part No.	Inductance(μ H) \pm 20%	Test Frequency	DCR(Ω)Max.	IDC(A)Max.
DR340-2-392	3.9	100kHz	0.015	6.5
DR340-2-472	4.7	100kHz	0.018	5.7
DR340-2-682	6.8	100kHz	0.023	4.9
DR340-2-103	10	100kHz	0.028	4.5
DR340-2-123	12	100kHz	0.038	4.0
DR340-2-153	15	100kHz	0.050	3.2
DR340-2-183	18	1kHz	0.057	3.1
DR340-2-223	22	1kHz	0.066	2.9
DR340-2-273	27	1kHz	0.080	2.8
DR340-2-333	33	1kHz	0.097	2.7
DR340-2-393	39	1kHz	0.132	2.1
DR340-2-473	47	1kHz	0.150	1.9
DR340-2-563	56	1kHz	0.190	1.8
DR340-2-683	68	1kHz	0.220	1.5
DR340-2-823	82	1kHz	0.260	1.3

Mechanical Outline

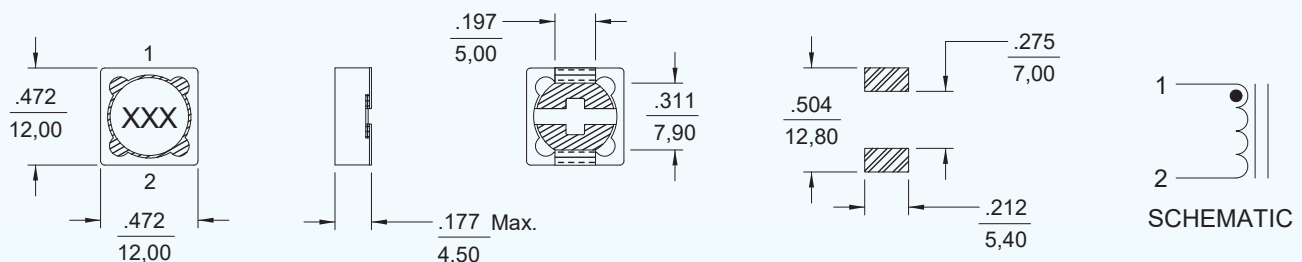

Notes:

1. Dimensions are shown in inches/millimeters
2. Unless otherwise specified, tolerance = Inches: ± 0.012
= Millimeters: $\pm 0,30$
3. IDC MAX based on the inductance being 75% of its initial value

4. Tape & reel quantity, 500 pcs/reel
5. Terminal finish is compliant to RoHS requirements
6. Solder in accordance with J-STD-002 Rev. D
7. Non-RoHS series parts 42-340-2-XXX are finished with leaded solder Sn60Pb40 or equivalent

DR340-3 SERIES

SHIELDED POWER INDUCTOR



Features

- Maximum Height: 6.0mm
- Footprint: 12mm x 12mm Max.
- Inductance Range from 1.3 μ H to 1.0mH
- Non-RoHS Versions are Available (Note 8)
- Operating Temp. -20°C to +80°C

Electrical Specifications at 25°C

Part No.	Inductance(μ H) \pm 20%	Test Frequency	DCR(Ω)Max.	IDC(A)Max.
DR340-3-132	1.3	7.96MHz	0.012	8.0
DR340-3-212	2.1	7.96MHz	0.014	7.0
DR340-3-312	3.1	7.96MHz	0.017	6.0
DR340-3-442	4.4	7.96MHz	0.020	5.0
DR340-3-582	5.8	7.96MHz	0.021	4.4
DR340-3-752	7.5	7.96MHz	0.024	4.2
DR340-3-103	10	1kHz	0.025	4.0
DR340-3-123	12	1kHz	0.027	3.5
DR340-3-153	15	1kHz	0.030	3.3
DR340-3-183	18	1kHz	0.034	3.0
DR340-3-223	22	1kHz	0.036	2.8
DR340-3-273	27	1kHz	0.051	2.3
DR340-3-333	33	1kHz	0.057	2.1
DR340-3-393	39	1kHz	0.068	2.0
DR340-3-473	47	1kHz	0.075	1.8
DR340-3-563	56	1kHz	0.110	1.7
DR340-3-683	68	1kHz	0.120	1.5
DR340-3-823	82	1kHz	0.140	1.4
DR340-3-104	100	1kHz	0.160	1.3
DR340-3-124	120	1kHz	0.170	1.1
DR340-3-154	150	1kHz	0.230	1.0
DR340-3-184	180	1kHz	0.290	0.9
DR340-3-224	220	1kHz	0.400	0.8
DR340-3-274	270	1kHz	0.460	0.75
DR340-3-334	330	1kHz	0.510	0.68
DR340-3-394	390	1kHz	0.690	0.65
DR340-3-474	470	1kHz	0.770	0.58
DR340-3-564	560	1kHz	0.860	0.54
DR340-3-684	680	1kHz	1.200	0.48
DR340-3-824	820	1kHz	1.340	0.43
DR340-3-105	1000	1kHz	1.530	0.40

Mechanical Outline

Notes:

1. All dimensions are shown in inches/millimeters
2. Unless otherwise specified, tolerance = Inches: ± 0.012
= Millimeters: $\pm 0,30$
3. IDC MAX based on the inductance being 75% of its initial value
4. Tape & reel quantity, 500 pcs/reel
5. Inductance tolerance values: 1.3 μ H – 7.5 μ H = +30% / -20%
6. Terminal finish is compliant to RoHS requirements
7. Solder in accordance with J-STD-002 Rev. D
8. Non-RoHS series parts 42-340-3-XXX are finished with leaded solder Sn60Pb40 or equivalent

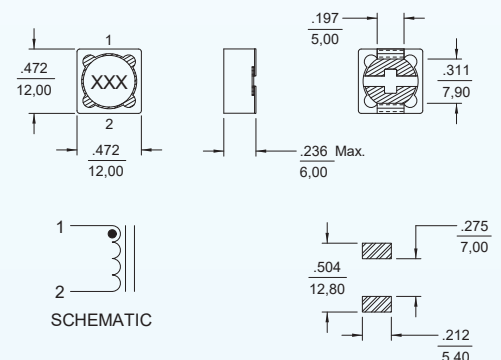

DR340-4 SERIES

SHIELDED POWER INDUCTOR



Features

- Maximum Height: 3.4mm
- Footprint: 7.3mm x 7.3mm
- Inductance Range from 10 H to 1.0mH
- Non-RoHS Versions are Available (Note 7)
- Operating Temp. -20°C to +80°C

Electrical Specifications at 25°C

Part No.	Inductance(μ H) \pm 20%	Test Frequency	DCR(Ω) Max.	IDC(A) Max.
DR340-4-103	10	1kHz	0.072	1.68
DR340-4-123	12	1kHz	0.098	1.52
DR340-4-153	15	1kHz	0.130	1.33
DR340-4-183	18	1kHz	0.140	1.20
DR340-4-223	22	1kHz	0.190	1.07
DR340-4-273	27	1kHz	0.210	0.96
DR340-4-333	33	1kHz	0.240	0.91
DR340-4-393	39	1kHz	0.320	0.77
DR340-4-473	47	1kHz	0.360	0.76
DR340-4-563	56	1kHz	0.470	0.68
DR340-4-683	68	1kHz	0.520	0.61
DR340-4-823	82	1kHz	0.690	0.57
DR340-4-104	100	1kHz	0.790	0.50
DR340-4-124	120	1kHz	0.890	0.49
DR340-4-154	150	1kHz	1.270	0.43
DR340-4-184	180	1kHz	1.450	0.39
DR340-4-224	220	1kHz	1.650	0.35
DR340-4-274	270	1kHz	2.310	0.32
DR340-4-334	330	1kHz	2.620	0.28
DR340-4-394	390	1kHz	2.940	0.26
DR340-4-474	470	1kHz	4.180	0.24
DR340-4-564	560	1kHz	4.670	0.22
DR340-4-684	680	1kHz	5.730	0.19
DR340-4-824	820	1kHz	6.540	0.18
DR340-4-105	1000	1kHz	9.440	0.16

Mechanical Outline

Notes:

1. Dimensions are shown in inches/millimeters
2. Unless otherwise specified, tolerance = Inches: \pm 0.012
= Millimeters: \pm 0,30
3. IDC MAX based on the inductance being 75% of its initial value
4. Tape & reel quantity, 250 pcs/reel
5. Terminal finish is compliant to RoHS requirements
6. Solder in accordance with J-STD-002 Rev. D
7. Non-RoHS series parts 42-340-4-XXX are finished with leaded solder Sn60Pb40 or equivalent

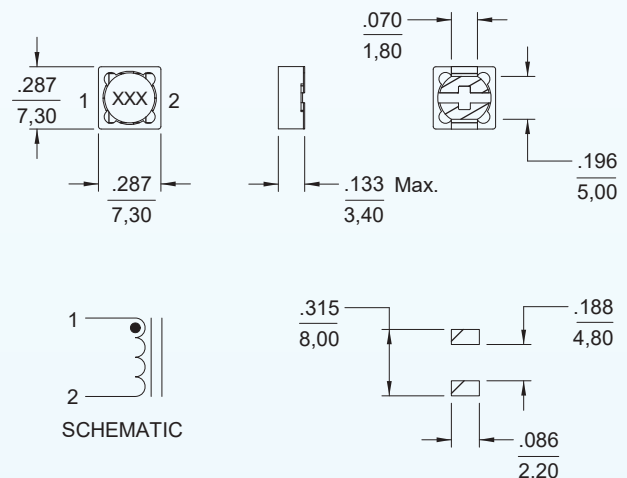

DR340-5 SERIES

SHIELDED POWER INDUCTOR



Features

- Maximum Height: 4.5mm
- Footprint: 7.3mm x 7.3mm
- Inductance Range from 10 H to 1.0mH
- Non-RoHS Versions are Available (Note 7)
- Operating Temp. -20°C to +80°C

Electrical Specifications at 25°C

Part No.	Inductance(μH) ±20%	Test Frequency	DCR(Ω)Max.	IDC(A)Max.
DR340-5-102	1μ ± 30%	1kHz	0.015	8.0
DR340-5-103	10	1kHz	0.049	1.84
DR340-5-123	12	1kHz	0.058	1.71
DR340-5-153	15	1kHz	0.081	1.47
DR340-5-183	18	1kHz	0.091	1.31
DR340-5-223	22	1kHz	0.110	1.23
DR340-5-273	27	1kHz	0.150	1.12
DR340-5-333	33	1kHz	0.170	0.96
DR340-5-393	39	1kHz	0.230	0.91
DR340-5-473	47	1kHz	0.260	0.88
DR340-5-563	56	1kHz	0.350	0.75
DR340-5-683	68	1kHz	0.380	0.69
DR340-5-823	82	1kHz	0.430	0.61
DR340-5-104	100	1kHz	0.610	0.60
DR340-5-124	120	1kHz	0.660	0.52
DR340-5-154	150	1kHz	0.880	0.46
DR340-5-184	180	1kHz	0.980	0.42
DR340-5-224	220	1kHz	1.170	0.36
DR340-5-274	270	1kHz	1.640	0.34
DR340-5-334	330	1kHz	1.860	0.32
DR340-5-394	390	1kHz	2.850	0.29
DR340-5-474	470	1kHz	3.010	0.26
DR340-5-564	560	1kHz	3.620	0.23
DR340-5-684	680	1kHz	4.630	0.22
DR340-5-824	820	1kHz	5.200	0.20
DR340-5-105	1000	1kHz	6.000	0.18

Mechanical Outline

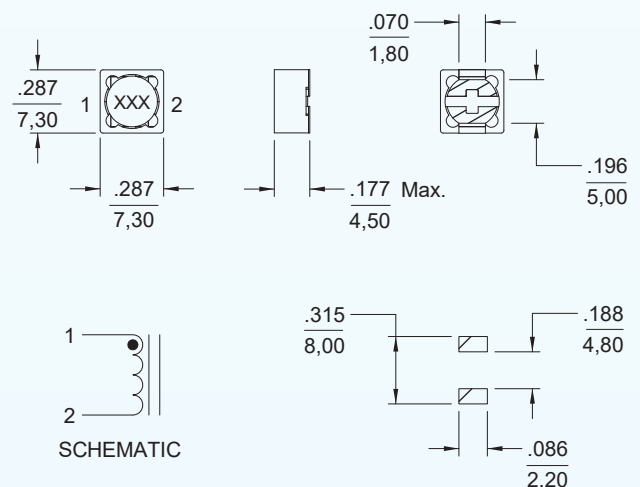

Notes:

1. Dimensions are shown in inches/millimeters
2. Unless otherwise specified, tolerance = Inches: ±0.012
= Millimeters: ±0.30
3. IDC MAX based on the inductance being 75% of its initial value
4. Tape & reel quantity, 500 pcs/reel
5. Terminal finish is compliant to RoHS requirements
6. Solder in accordance with J-STD-002 Rev. D
7. Non-RoHS series parts 42-340-5-XXX are finished with leaded solder Sn60Pb40 or equivalent

DR340-6 SERIES

SHIELDED SMD INDUCTOR



Features

- Low Profile Surface Mount Design
- Low Radiation (with magnetic shield)
- Inductance Range from 2.9 μ H to 330 μ H
- Operating Temperature Range: -20°C to +80°C
- Tinned Leads with Lead Solder is Available (note 7)

Electrical Specifications at 25°C

Part No.	Inductance(μ H)	Measuring Frequency@0.25V	DCR(Ohm)Max.	Rated DC Current(A)Max.
DR340-6-292	2.9+40%-20%	7.96MHz	0.068	1.94
DR340-6-402	4.0+40%-20%	7.96MHz	0.08	1.63
DR340-6-552	5.5+40%-20%	7.96MHz	0.096	1.40
DR340-6-103	10 \pm 20%	1KHz	0.15	1.10
DR340-6-123	12 \pm 20%	1KHz	0.2	1.00
DR340-6-153	15 \pm 20%	1KHz	0.23	0.90
DR340-6-183	18 \pm 20%	1KHz	0.27	0.80
DR340-6-223	22 \pm 20%	1KHz	0.34	0.74
DR340-6-273	27 \pm 20%	1KHz	0.38	0.66
DR340-6-333	33 \pm 20%	1KHz	0.45	0.59
DR340-6-393	39 \pm 20%	1KHz	0.49	0.54
DR340-6-473	47 \pm 20%	1KHz	0.69	0.5
DR340-6-563	56 \pm 20%	1KHz	0.78	0.46
DR340-6-683	68 \pm 20%	1KHz	1.07	0.42
DR340-6-823	82 \pm 20%	1KHz	1.21	0.38
DR340-6-104	100 \pm 20%	1KHz	1.39	0.34
DR340-6-124	120 \pm 20%	1KHz	1.90	0.31
DR340-6-154	150 \pm 20%	1KHz	2.18	0.28
DR340-6-184	180 \pm 20%	1KHz	2.77	0.26
DR340-6-224	220 \pm 20%	1KHz	3.12	0.23
DR340-6-274	270 \pm 20%	1KHz	4.38	0.22
DR340-6-334	330 \pm 20%	1KHz	4.94	0.19

Mechanical Outline

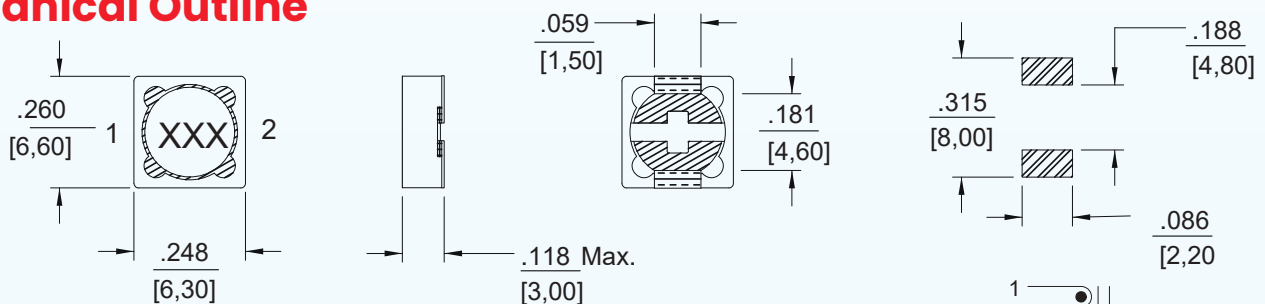

Notes:

1. Dimensions are shown in inches/millimeters
2. Unless otherwise specified, tolerance = Inches: ± 0.012
= Millimeters: $\pm 0,30$
3. IDC MAX based on the inductance being 75% of its initial value
4. Tape & reel quantity, 1500 pcs/reel
5. Terminal finish is compliant to RoHS requirements 5.
6. Solder in accordance with J-STD-002 Rev. D
7. Non-RoHS series parts 42-340-6-XXX are finished with leaded solder Sn60Pb40 or equivalent

DR350-1 SERIES

SHIELDED SMD INDUCTOR



Features

- Low Profile Surface Mount Design
- Flat Top for Pick and Place
- Inductance Range from 3.3 μ H to 47.0 μ H
- Operating Temp. -40°C to +85°C
- Tinned Leads with Leaded Solder is Available (note 7)

Electrical Specifications at 25°C

Part No.	Inductance (μ H) \pm 20%	DCR (Ω) \pm 20%	I _{rms} (A) Max.	I _{sat} (A) Max.
DR350-1-332	3.3	0.037	1.60	1.60
DR350-1-472	4.7	0.045	1.50	1.50
DR350-1-682	6.8	0.059	1.30	1.30
DR350-1-103	10.0	0.083	1.10	1.10
DR350-1-153	15.0	0.130	0.88	0.88
DR350-1-223	22.0	0.180	0.75	0.75

Mechanical Outline

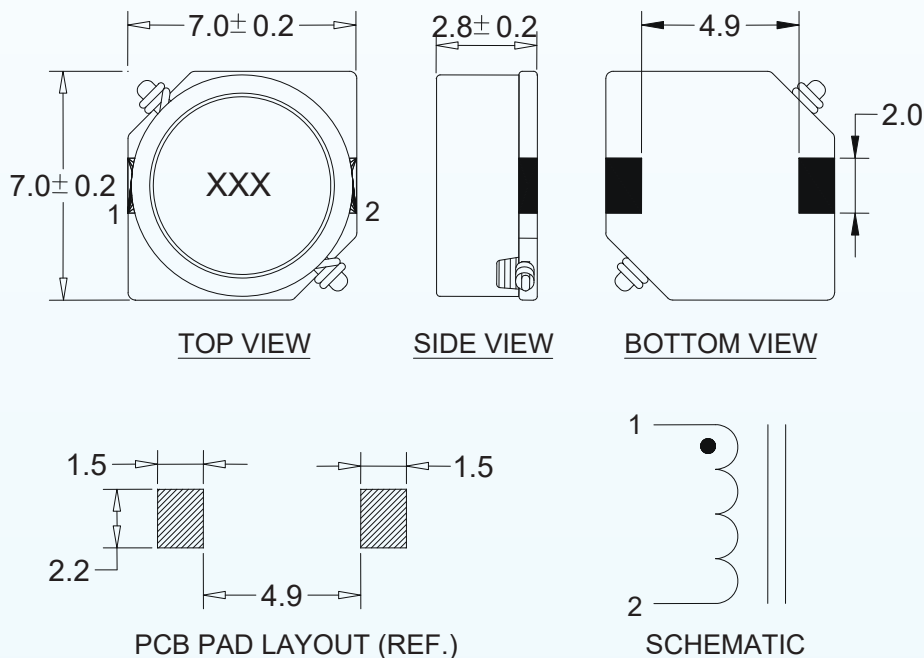

Notes:

1. All dimensions are shown in millimeter "mm"
2. General tolerance \pm 0.2mm, unless other specified
3. Inductance Test: 1kHz, 0.5V_{rms}
4. I_{rms} for an approximate 45°C temperature rise
5. I_{sat} for an approximate 20% drop maximum of the nominal value
6. Tape and reel quantity, 1000 pcs/reel
7. For non-RoHS parts replace DR prefix with 42- (e.g. DR350-1 becomes 42-350-1)
8. Terminal finish is compliant to RoHS requirements. Solder in accordance with J-STD-020D

DR350-2 SERIES

SHIELDED SMD INDUCTOR



Features

- Low Profile Surface Mount Design
- Flat Top for Pick and Place
- Inductance Range from 3.3 μ H to 100.0 μ H
- Operating Temp. -40°C to +85°C
- Tinned Leads with Leaded Solder is Available (note 7)

Electrical Specifications at 25°C

Part No.	Inductance (μ H) \pm 20%	DCR (Ω) \pm 20%	I rms (A) Max.	I sat (A) Max.
DR350-2-332	3.3	0.023	1.80	1.80
DR350-2-472	4.7	0.036	1.60	1.60
DR350-2-682	6.8	0.041	1.50	1.50
DR350-2-103	10.0	0.053	1.30	1.30
DR350-2-153	15.0	0.084	1.00	1.00
DR350-2-223	22.0	0.110	0.86	0.86

Mechanical Outline

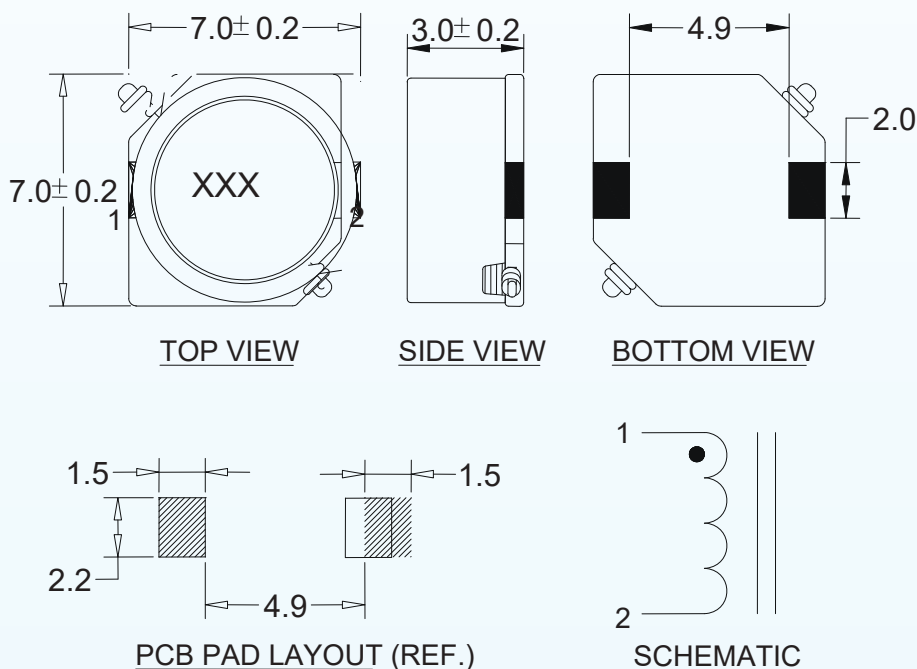

Notes:

1. All dimensions are shown in millimeter "mm"
2. General tolerance \pm 0.2mm, unless other specified
3. Inductance Test: 1kHz, 0.5Vrms
4. I_{rms} for an approximate 45°C temperature rise
5. I_{sat} for an approximate 20% drop maximum of the nominal value
6. Tape and reel quantity, 1000 pcs/reel
7. For non-RoHS parts replace DR prefix with 42- (e.g. DR350-2 becomes 42-350-2)
8. Terminal finish is compliant to RoHS requirements. Solder in accordance with J-STD-020D.

DR350-3 SERIES

SHIELDED SMD INDUCTOR



Features

- Low Profile Surface Mount Design
- Flat Top for Pick and Place
- Inductance Range from 3.3 μ H to 1000.0 μ H
- Operating Temp. -40°C to +85°C
- Tinned Leads with Leaded Solder is Available (note 7)

Electrical Specifications at 25°C

Part No.	Inductance (μ H) \pm 20%	DCR (Ω) \pm 20%	I _{rms} (A) Max.	I _{sat} (A) Max.
DR350-3-332	3.3	0.023	1.90	1.90
DR350-3-472	4.7	0.036	1.70	1.70
DR350-3-682	6.8	0.041	1.60	1.60
DR350-3-103	10.0	0.053	1.40	1.40
DR350-3-153	15.0	0.075	1.10	1.10
DR350-3-223	22.0	0.110	0.96	0.96
DR350-3-333	33.0	0.160	0.75	0.75
DR350-3-473	47.0	0.240	0.67	0.67
DR350-3-683	68.0	0.310	0.59	0.59
DR350-3-104	100.0	0.450	0.45	0.45
DR350-3-154	150.0	0.650	0.37	0.37

Mechanical Outline

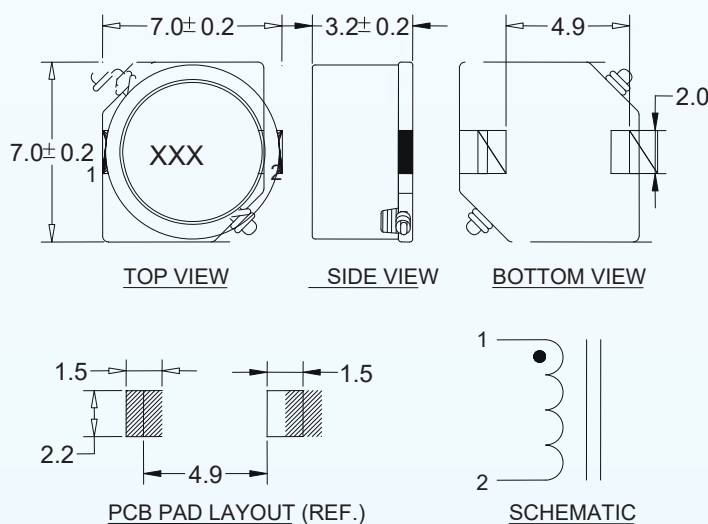

Notes:

1. All dimensions are shown in millimeter "mm"
2. General tolerance \pm 0.2mm, unless other specified
3. Inductance Test: 1kHz, 0.5Vrms
4. I_{rms} for an approximate 45°C temperature rise
5. I_{sat} for an approximate 20% drop maximum of the nominal value
6. Tape and reel quantity, 1000 pcs/reel
7. For non-RoHS parts replace DR prefix with 42- (e.g. DR350-3 becomes 42-350-3)
8. Terminal finish is compliant to RoHS requirements. Solder in accordance with J-STD-020D

DR350-4 SERIES

SHIELDED SMD INDUCTOR



Features

- Low Profile Surface Mount Design
- Flat Top for Pick and Place
- Inductance Range from 1.0 μ H to 1000.0 μ H
- Operating Temp. -40°C to +85°C
- Tinned Leads with Leaded Solder is Available (note 9)

Electrical Specifications at 25°C

Part No.	Inductance (μ H) \pm 20%	DCR (Ω) \pm 20%	I _{rms} (A) Max.	I _{sat} (A) Max.
DR350-4-102	1.0	0.015	3.50	3.50
DR350-4-332	3.3	0.020	2.30	2.50
DR350-4-472	4.7	0.030	2.10	2.00
DR350-4-682	6.8	0.039	1.74	1.70
DR350-4-103	10.0	0.036	1.78	1.30
DR350-4-153	15.0	0.052	1.53	1.10
DR350-4-223	22.0	0.061	1.34	0.90
DR350-4-333	33.0	0.096	1.09	0.82
DR350-4-473	47.0	0.125	0.92	0.75
DR350-4-683	68.0	0.175	0.77	0.60
DR350-4-104	100.0	0.250	0.65	0.50

Mechanical Outline

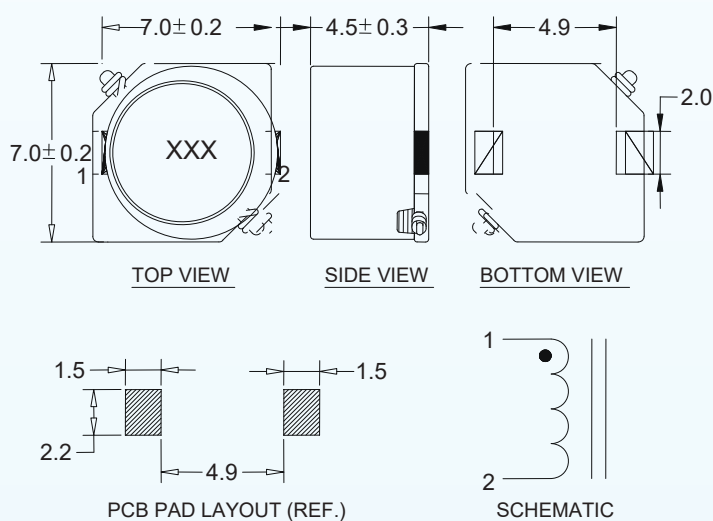

Notes:

1. All dimensions are shown in millimeter "mm"
2. General tolerance \pm 0.2mm, unless other specified
3. Inductance Test: 1kHz, 0.5V_{rms}
4. I_{rms} for an approximate 45°C temperature rise
5. I_{sat} for an approximate 20% drop maximum of the nominal value
6. Tape and reel quantity, 1000 pcs/reel
7. Terminal finish is compliant to RoHS requirements
8. Solder in accordance with J-STD-002 Rev. D
9. Non-RoHS series parts 42-350-4-XXX are finished with leaded solder Sn60Pb40 or equivalent

DR350-5 SERIES

SHIELDED SMD INDUCTOR



Features

- Low Profile Surface Mount Design
- Flat Top for Pick and Place
- Inductance Range from 10.0 μ H to 1500.0 μ H
- Operating Temp. -40°C to +85°C
- Tinned Leads with Leaded Solder is Available (note 7)

Electrical Specifications at 25°C

Part No.	Inductance (μ H) \pm 20%	DCR (Ω) \pm 20%	I _{rms} (A) Max.	I _{sat} (A) Max.
DR350-5-103	10.0	0.036	2.50	3.00
DR350-5-153	15.0	0.047	2.20	2.40
DR350-5-223	22.0	0.059	1.90	2.10
DR350-5-333	33.0	0.082	1.70	1.60
DR350-5-473	47.0	0.100	1.50	1.40
DR350-5-683	68.0	0.140	1.30	1.20
DR350-5-104	100.0	0.200	1.10	1.00
DR350-5-154	150.0	0.350	0.81	0.79
DR350-5-224	220.0	0.470	0.70	0.65
DR350-5-334	330.0	0.680	0.58	0.54
DR350-5-474	470.0	1.030	0.47	0.47

Mechanical Outline

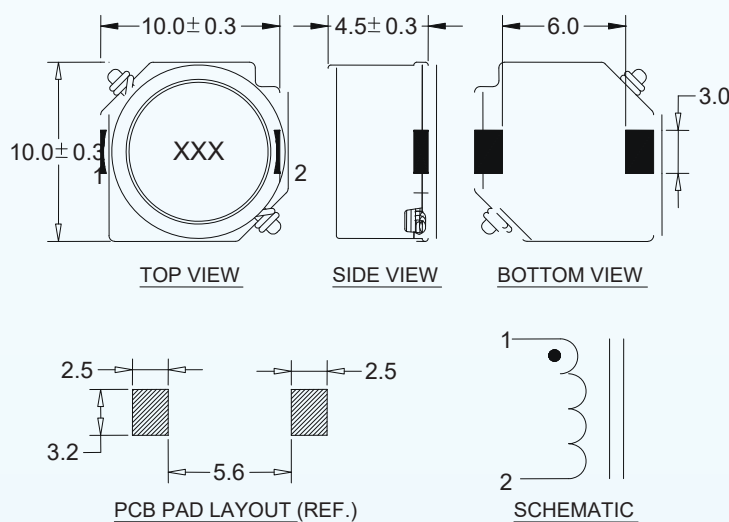

Notes:

1. All dimensions are shown in millimeter "mm"
2. General tolerance \pm 0.2mm, unless other specified
3. Inductance Test: 1kHz, 0.5V_{rms}
4. I_{rms} for an approximate 45°C temperature rise
5. I_{sat} for an approximate 20% drop maximum of the nominal value
6. Tape and reel quantity, 750 pcs/reel
7. For non-RoHS parts replace DR prefix with 42- (e.g. DR350-5 becomes 42-350-5)
8. Terminal finish is compliant to RoHS requirements. Solder in accordance with J-STD-020D.

DR350-6 SERIES

SHIELDED SMD INDUCTOR



Features

- Low Profile Surface Mount Design
- Flat Top for Pick and Place
- Inductance Range from 6.0 μ H to 1500.0 μ H
- Operating Temp. -40°C to +85°C
- Tinned Leads with Leaded Solder is Available (note 7)

Electrical Specifications at 25°C

Part No.	Inductance (μ H)	DCR (m Ω) \pm 20%	I _{rms} (A) Max.	I _{sat} (A) Max.
DR350-6-602	6.0 \pm 30%	16.4	4.9	3.6
DR350-6-103	10.0 \pm 20%	21.5	4.3	3.4
DR350-6-153	15.0 \pm 20%	25.9	3.9	2.8
DR350-6-223	22.0 \pm 20%	33.8	3.4	2.3
DR350-6-333	33.0 \pm 20%	41.5	3.1	1.9
DR350-6-473	47.0 \pm 20%	61.8	2.5	1.6
DR350-6-683	68.0 \pm 20%	83.2	2.2	1.3
DR350-6-104	100.0 \pm 20%	117.0	1.8	1.1
DR350-6-154	150.0 \pm 20%	190.0	1.4	0.88
DR350-6-224	220.0 \pm 20%	270.0	1.2	0.72

Mechanical Outline

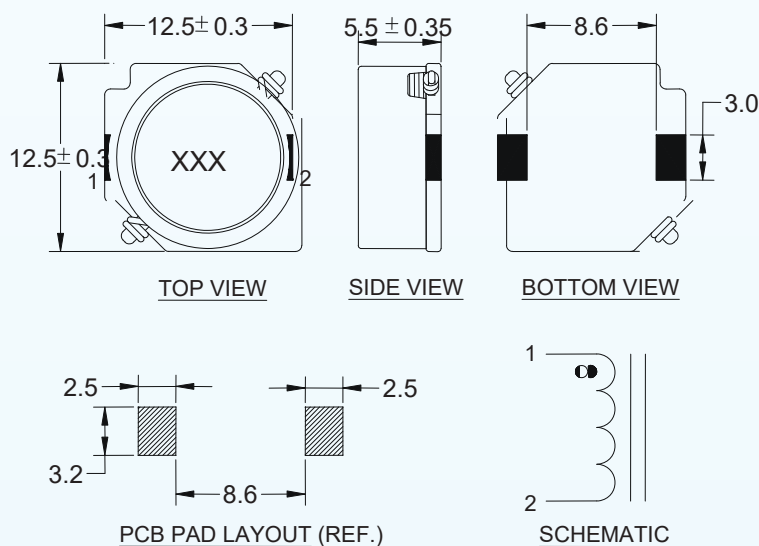

Notes:

1. All dimensions are shown in millimeter "mm"
2. General tolerance \pm 0.2mm, unless other specified
3. Inductance Test: 1kHz, 0.5Vrms
4. I_{rms} for an approximate 45°C temperature rise
5. I_{sat} for an approximate 20% drop maximum of the nominal value
6. Tape and reel quantity, 500 pcs/reel
7. For non-RoHS parts replace DR prefix with 42- (e.g. DR350-6 becomes 42-350-6)
8. Terminal finish is compliant to RoHS requirements. Solder in accordance with J-STD-020D.

DR350-7 SERIES

SHIELDED SMD INDUCTOR



Features

- Low Profile Surface Mount Design
- Flat Top for Pick and Place
- Inductance Range from 2.0 μ H to 150.0 μ H
- Operating Temp. -40°C to +85°C
- Tinned Leads with Leaded Solder is Available (note 7)

Electrical Specifications at 25°C

Part No.	Inductance (μ H)	DCR (m Ω) \pm 20%	I _{rms} (A) Max.	I _{sat} (A) Max.
DR350-7-202	2.0 \pm 30%	11.7	6.2	10.0
DR350-7-422	4.2 \pm 30%	15.0	5.5	7.3
DR350-7-702	7.0 \pm 20%	17.7	5.0	5.7
DR350-7-103	10.0 \pm 20%	20.2	4.8	5.0
DR350-7-153	15.0 \pm 20%	23.7	4.4	4.2
DR350-7-223	22.0 \pm 20%	31.6	3.8	3.5
DR350-7-333	33.0 \pm 20%	40.6	3.4	2.8
DR350-7-473	47.0 \pm 20%	57.8	2.8	2.4
DR350-7-683	68.0 \pm 20%	78.7	2.4	2.0
DR350-7-104	100.0 \pm 20%	123.0	1.9	1.6

Mechanical Outline

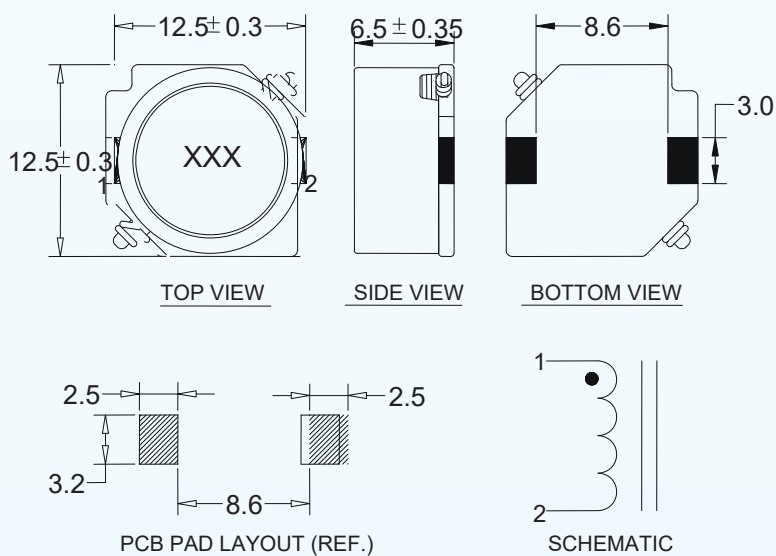

Notes:

1. All dimensions are shown in millimeter "mm"
2. General tolerance \pm 0.2mm, unless other specified
3. Inductance Test: 1kHz, 0.5V_{rms}
4. I_{rms} for an approximate 45°C temperature rise
5. I_{sat} for an approximate 20% drop maximum of the nominal value
6. Tape and reel quantity, 500 pcs/reel
7. For non-RoHS parts replace DR prefix with 42- (e.g. DR350-7 becomes 42-350-7)
8. Terminal finish is compliant to RoHS requirements. Solder in accordance with J-STD-020D.

DR350-8 SERIES

SHIELDED SMD INDUCTOR



Features

- Low Profile Surface Mount Design
- Flat Top for Pick and Place
- Inductance Range from 1.2 μ H to 220.0 μ H
- Operating Temp. -40°C to +85°C
- Tinned Leads with Leaded Solder is Available (note 7)

Electrical Specifications at 25°C

Part No.	Inductance (μ H)	DCR (m Ω)Max.	I rms (A)Max.	I sat (A)Max.
DR350-8-122	1.2 \pm 30%	8.28	8.2	13.0
DR350-8-272	2.7 \pm 30%	11.28	7.0	10.0
DR350-8-392	3.9 \pm 30%	12.48	6.7	9.0
DR350-8-562	5.6 \pm 30%	13.92	6.3	7.8
DR350-8-682	6.8 \pm 30%	15.72	5.9	7.2
DR350-8-103	10.0 \pm 20%	18.72	5.4	5.5
DR350-8-153	15.0 \pm 20%	22.08	5.0	4.7
DR350-8-223	22.0 \pm 20%	31.56	4.0	4.0
DR350-8-333	33.0 \pm 20%	47.40	3.4	3.2

Mechanical Outline

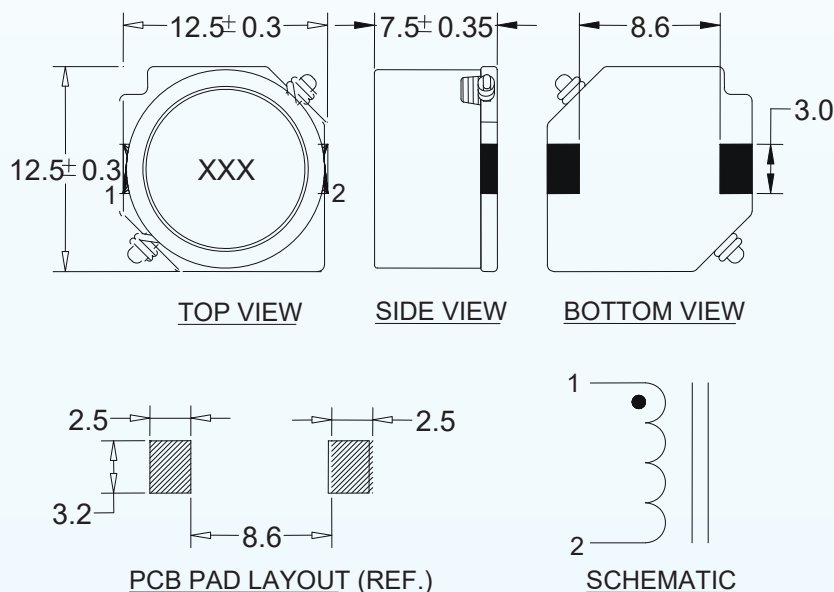

Notes:

1. All dimensions are shown in millimeter "mm"
2. General tolerance \pm 0.2mm, unless other specified
3. Inductance Test: 1kHz, 0.5Vrms
4. I_{rms} for an approximate 45°C temperature rise
5. I_{sat} for an approximate 20% drop maximum of the nominal value
6. Tape and reel quantity, 350 pcs/reel
7. For non-RoHS parts replace DR prefix with 42- (e.g. DR350-8 becomes 42-350-8)
8. Terminal finish is compliant to RoHS requirements. Solder in accordance with J-STD-020D.

DR350-9 SERIES

SHIELDED SMD INDUCTOR



Features

- Low Profile Surface Mount Design
- Flat Top for Pick and Place
- Inductance Range from 4.7 μ H to 100.0 μ H
- Operating Temp. -40°C to +85°C
- Tinned Leads with Leaded Solder is Available (note 7)

Electrical Specifications at 25°C

Part No.	Inductance (μ H)	DCR (m Ω)Max.	I _{rms} (A)Max.	I _{sat} (A)Max.
DR350-9-472	4.7	0.036	2.50	1.60
DR350-9-682	6.8	0.052	2.20	1.50
DR350-9-103	10.0	0.068	1.80	1.30
DR350-9-153	15.0	0.100	1.40	1.00
DR350-9-223	22.0	0.120	1.30	0.77
DR350-9-333	33.0	0.180	1.10	0.69
DR350-9-473	47.0	0.270	0.92	0.59
DR350-9-683	68.0	0.390	0.78	0.50
DR350-9-104	100.0	0.620	0.64	0.42

Mechanical Outline

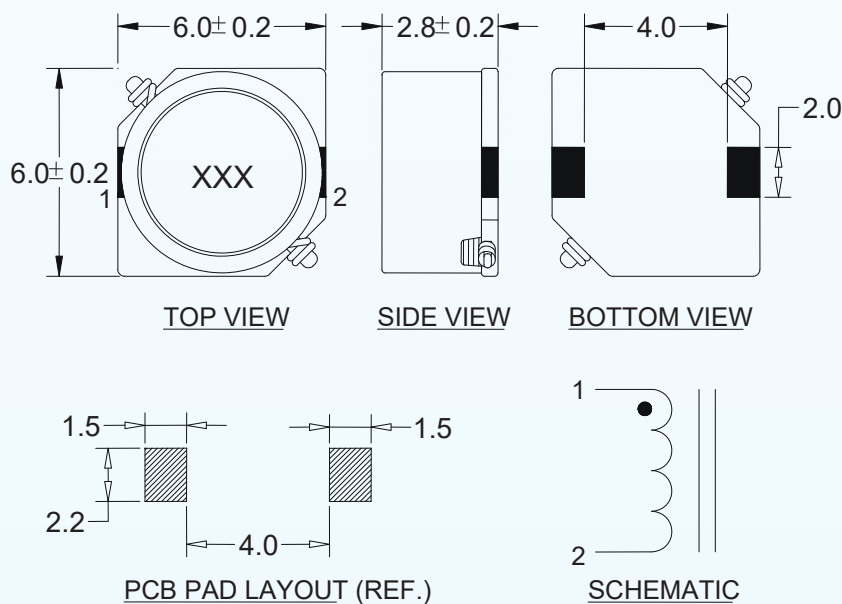

Notes:

1. All dimensions are shown in millimeter "mm"
2. General tolerance ± 0.2 mm, unless other specified
3. Inductance Test: 1kHz, 0.5V_{rms}
4. I_{rms} for an approximate 45°C temperature rise
5. I_{sat} for an approximate 20% drop maximum of the nominal value
6. Tape and reel quantity, 1000 pcs/reel
7. For non-RoHS parts replace DR prefix with 42- (e.g. DR350-9 becomes 42-350-9)
8. Terminal finish is compliant to RoHS requirements. Solder in accordance with J-STD-020D

DR374-1 SERIES

SMT COUPLED POWER INDUCTORS



Features

- Inductance range: 105nH to 200nH
- High Saturation Current, up to 125A
- Height: 11.0 mm Max
- Footprint: 12.0 x 6.0 Max

Part No.	L@100kHz,1V (nH) ± 15%	DCR (1-4) (mΩ) ± 10%	DCR (2-3) (mΩ) ± 10%	I _{sat} @ 80% L (A)		I _r (1-3) @ΔT=40°C (A)	I _r (2-4) @ΔT=40°C (A)
				25°C	100°C		
DR374-1-111	105	0.125	0.37	125	106	77	45
DR374-1-121	120			102	87		
DR374-1-151	150			84	71		
DR374-1-171	170			70	60		
DR374-1-201	200			58	50		

Mechanical Outline

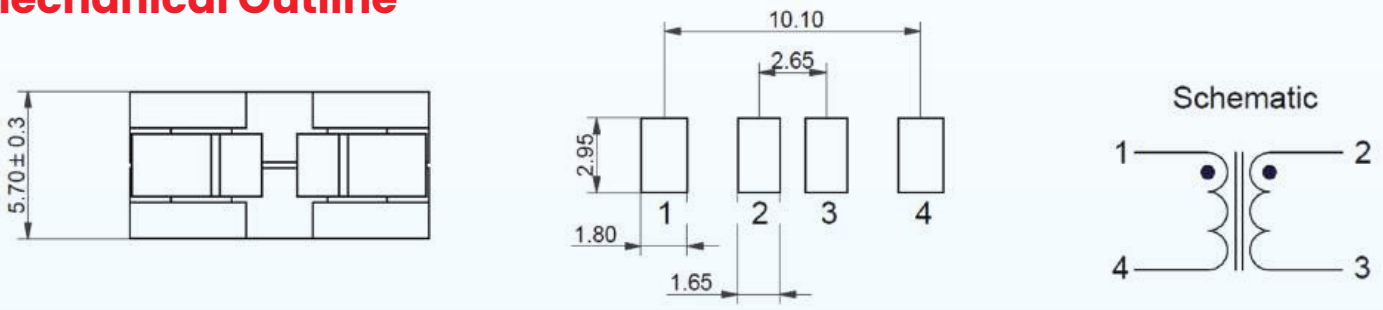

SUGGESTED PCB LAYOUT

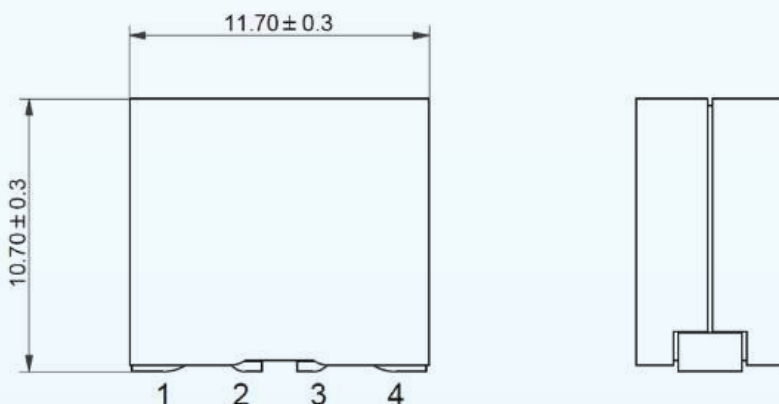

North America

Datatronics, United States
28151 Highway 74 Menifee, CA 92585
Tel: +951 928 7700

Asia

Datatronic, Hong Kong
19/F, North Point Industrial Building, 499 King's
Road, North Point HK
Tel: +852 25648477